

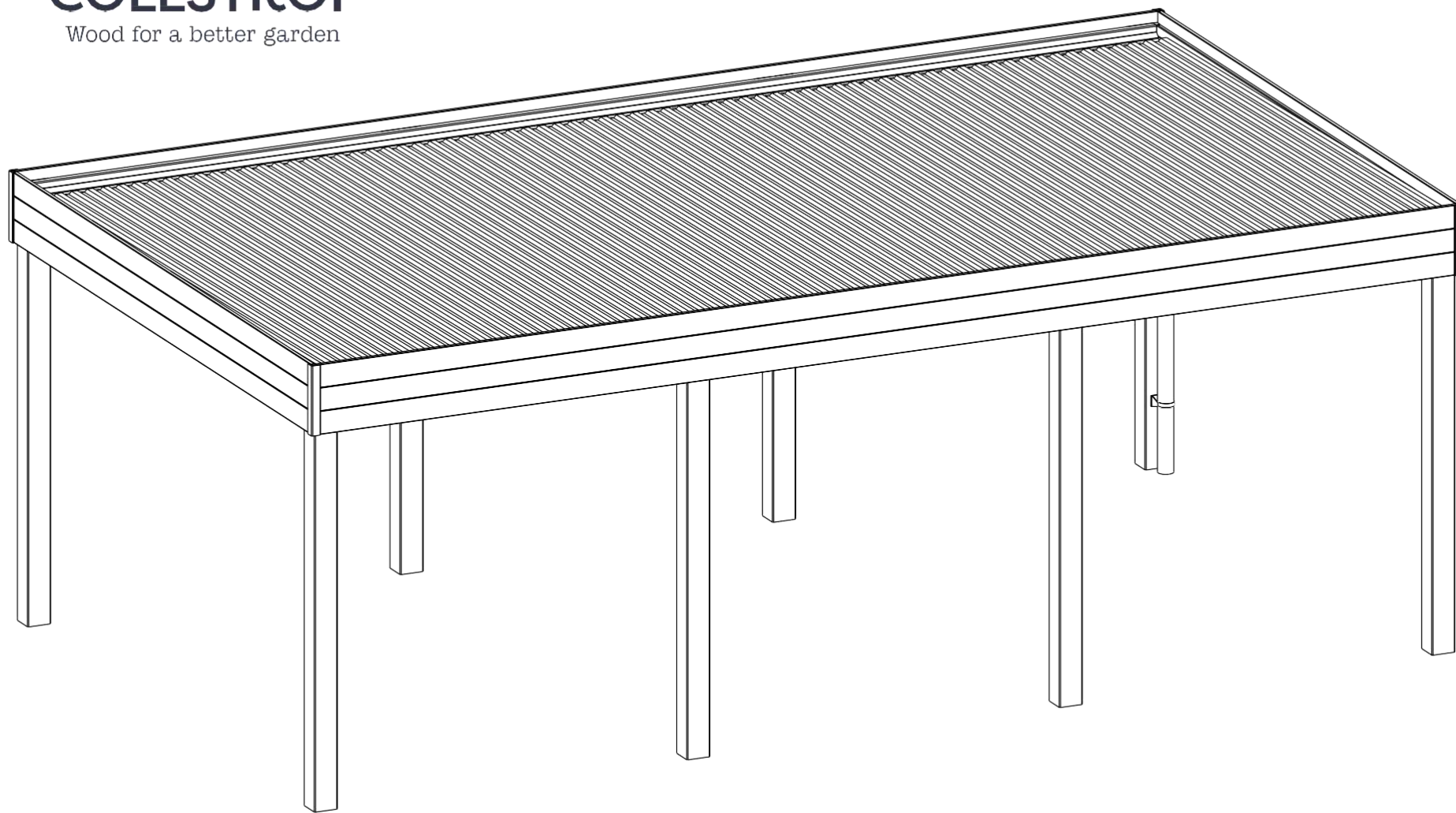

COLLSTROP
Wood for a better garden

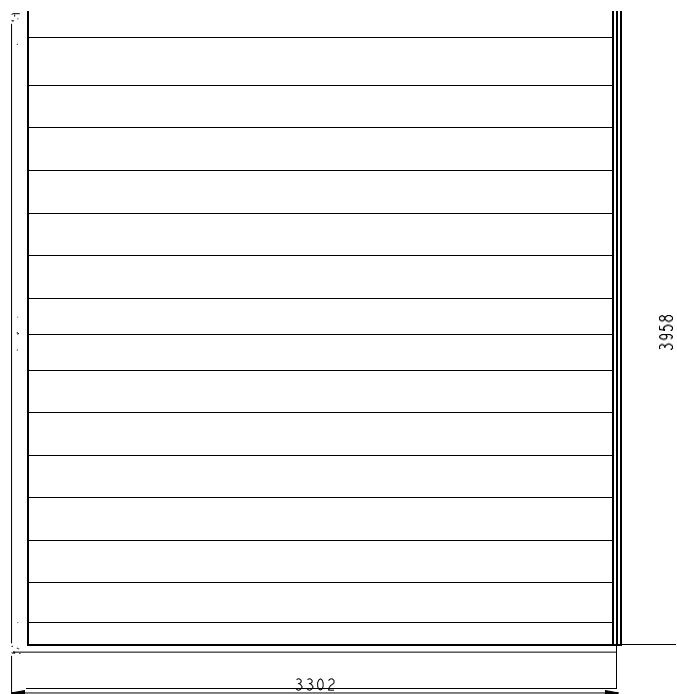

KA.1

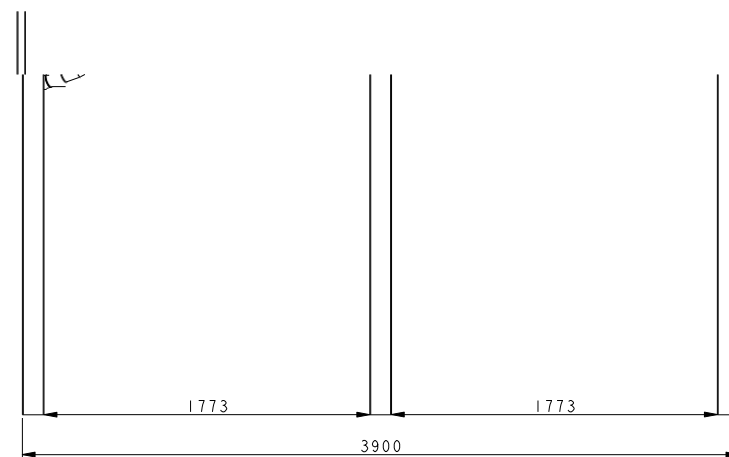
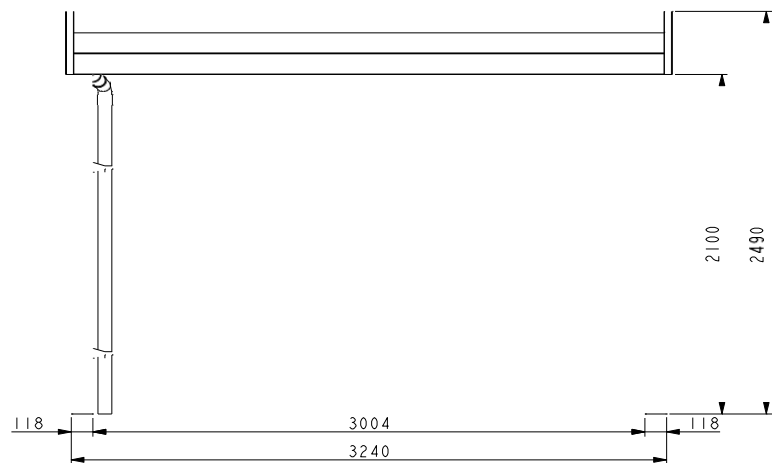

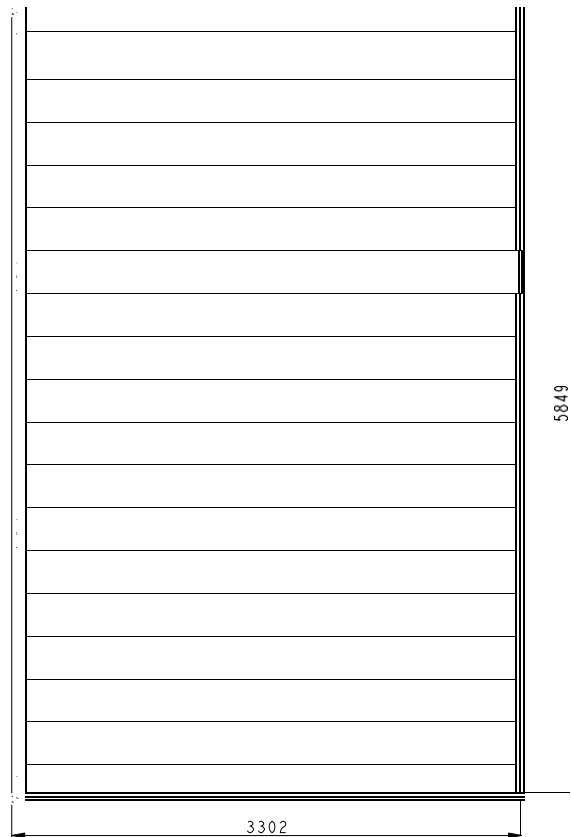
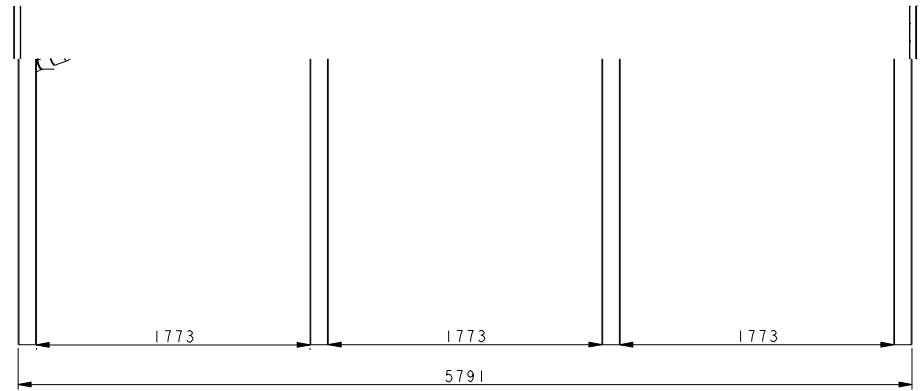
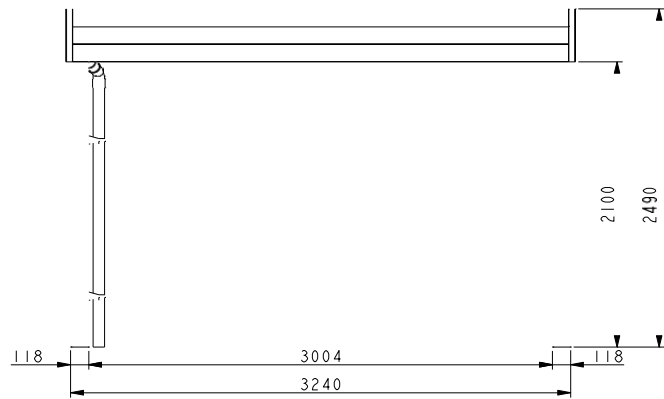
KA.12



KA.13

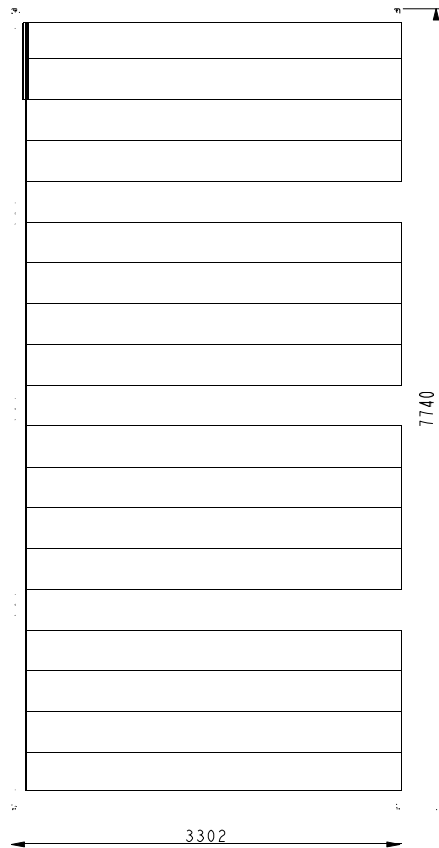
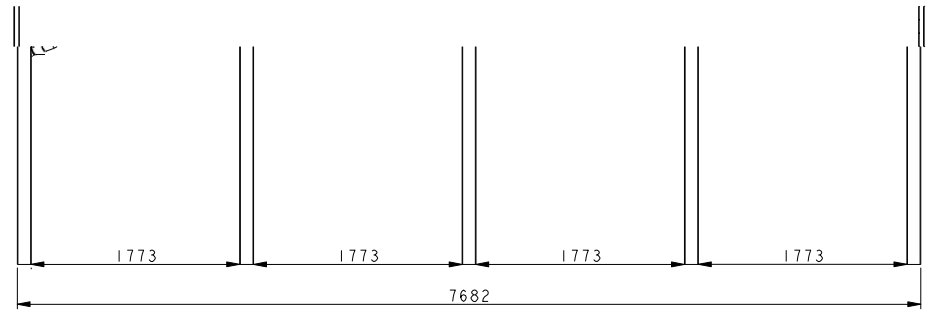
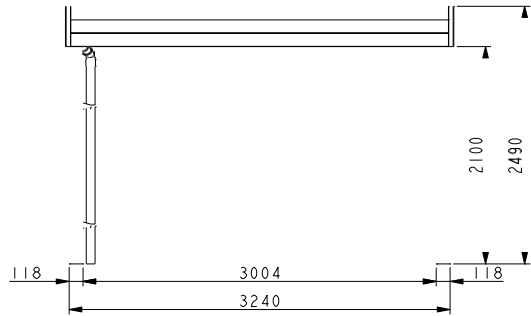

KA.14

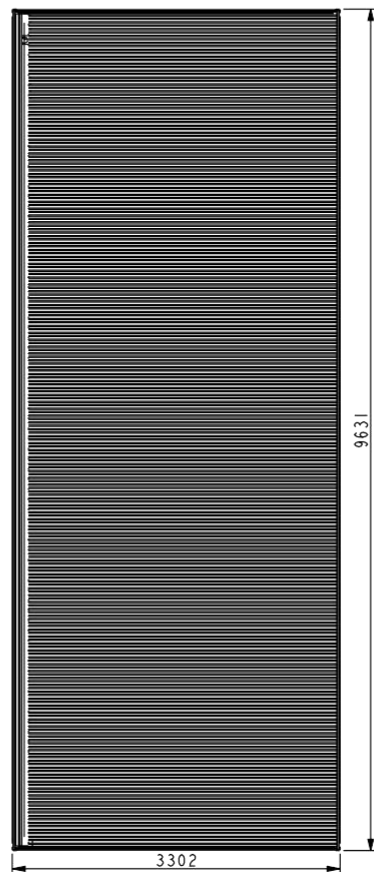
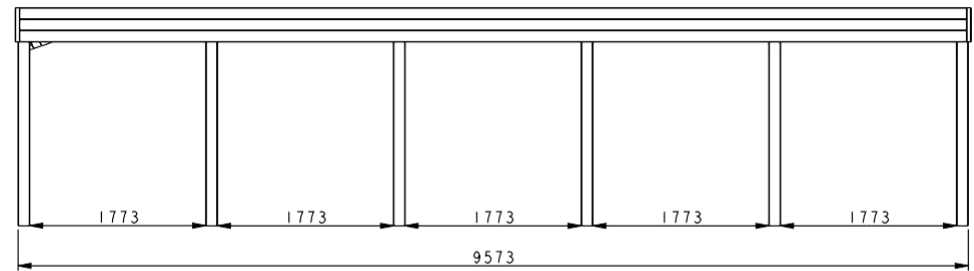
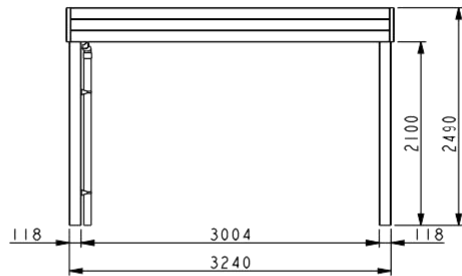

KA.15

FUNDERING
FONDATION

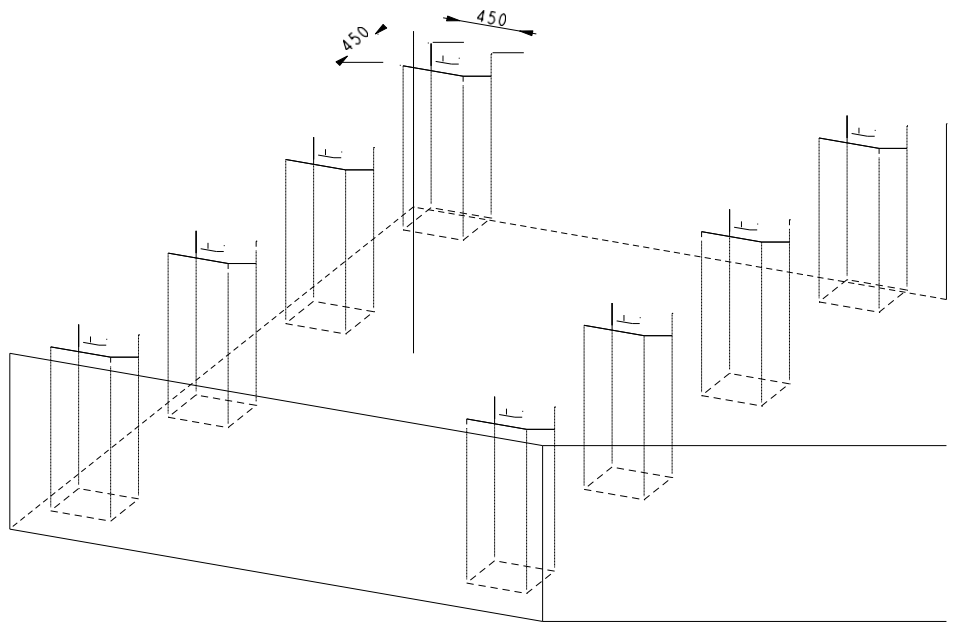
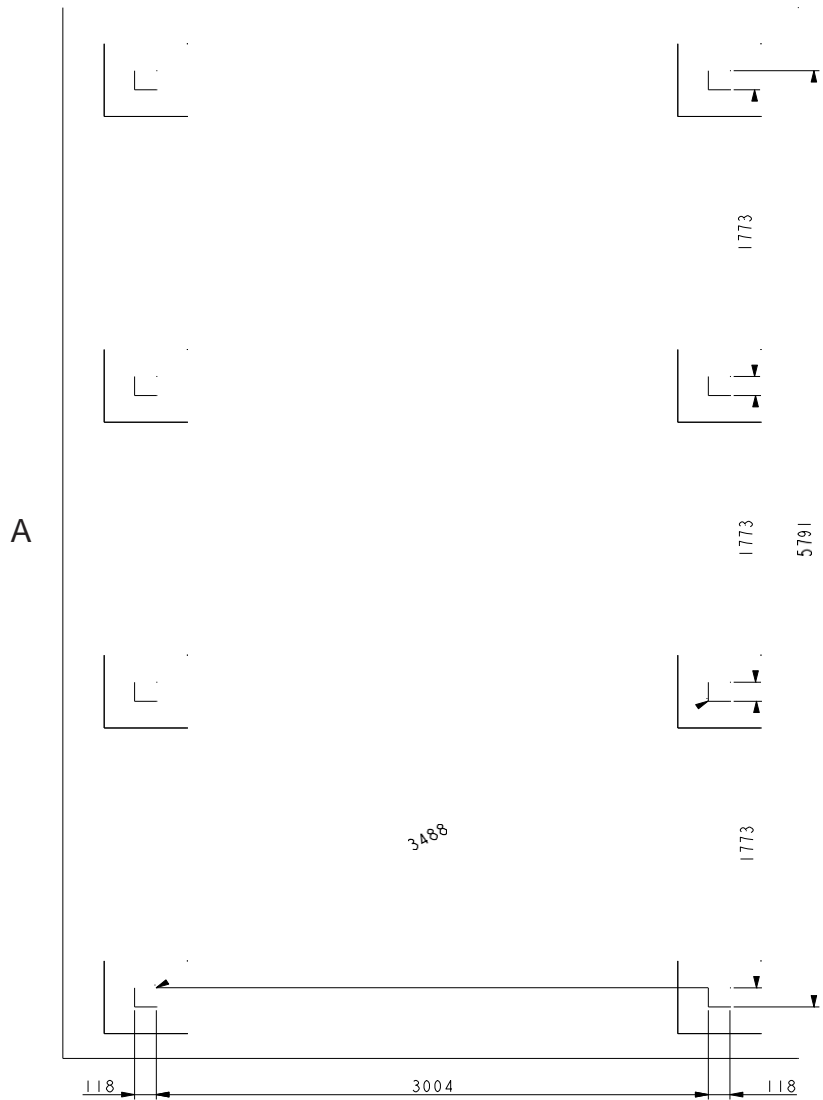

A	
KA.12	3X2
KA.13	4X2
KA.14	5X2
KA.15	6X2

FUNDERING
FONDATION

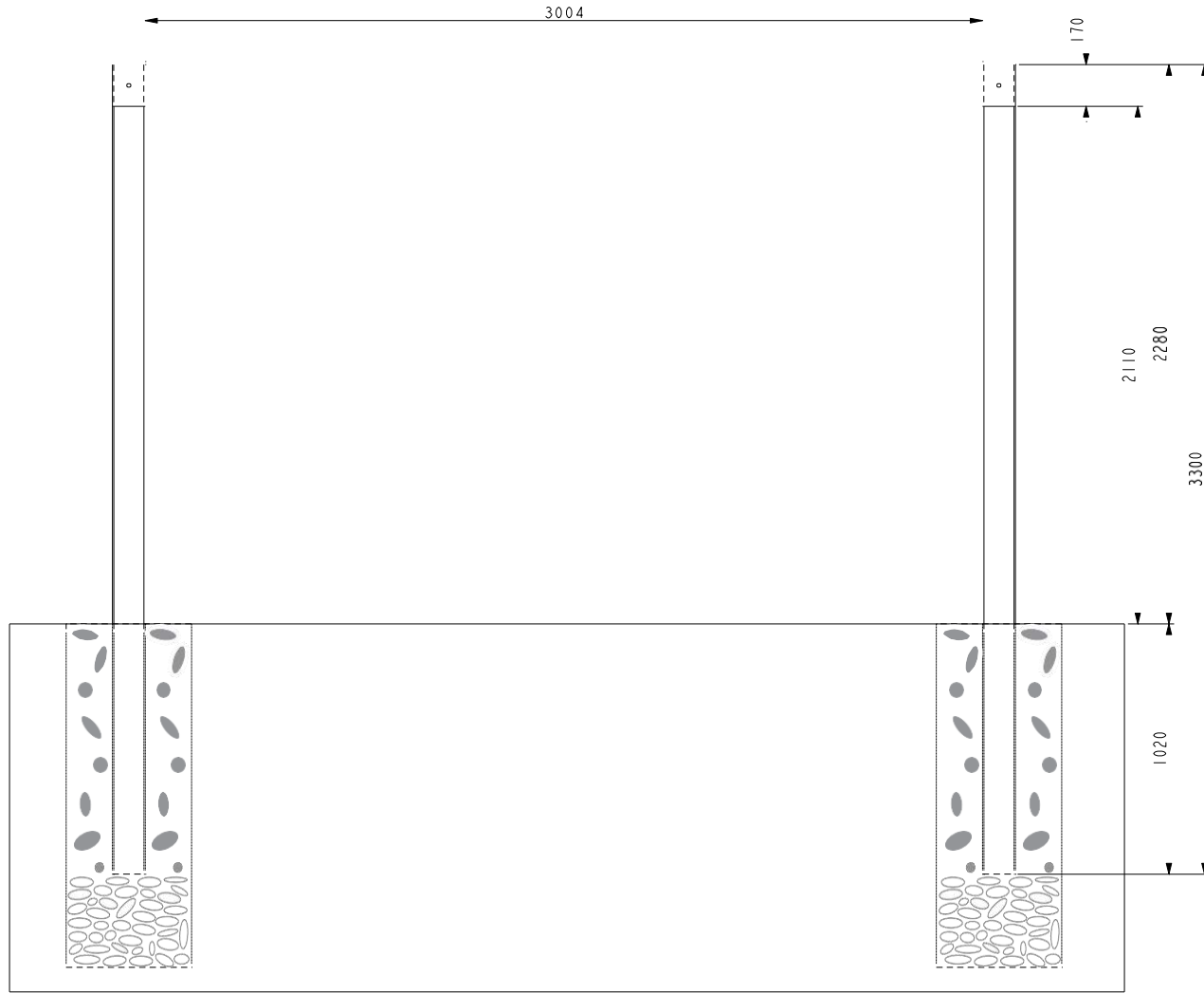

CONSTRUCTIE zonder berging
CONSTRUCTION sans abri

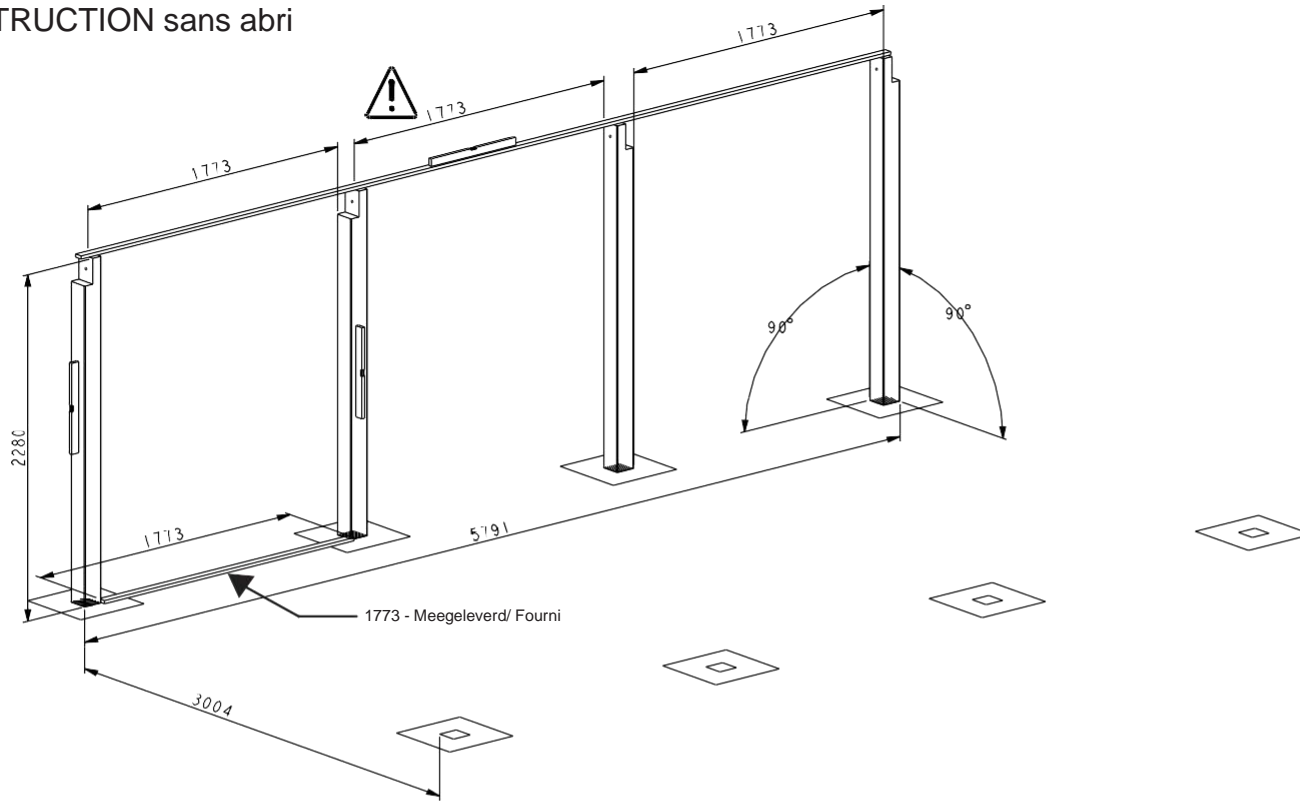

CONSTRUCTIE (met berging) p.34
CONSTRUCTION (avec abri)

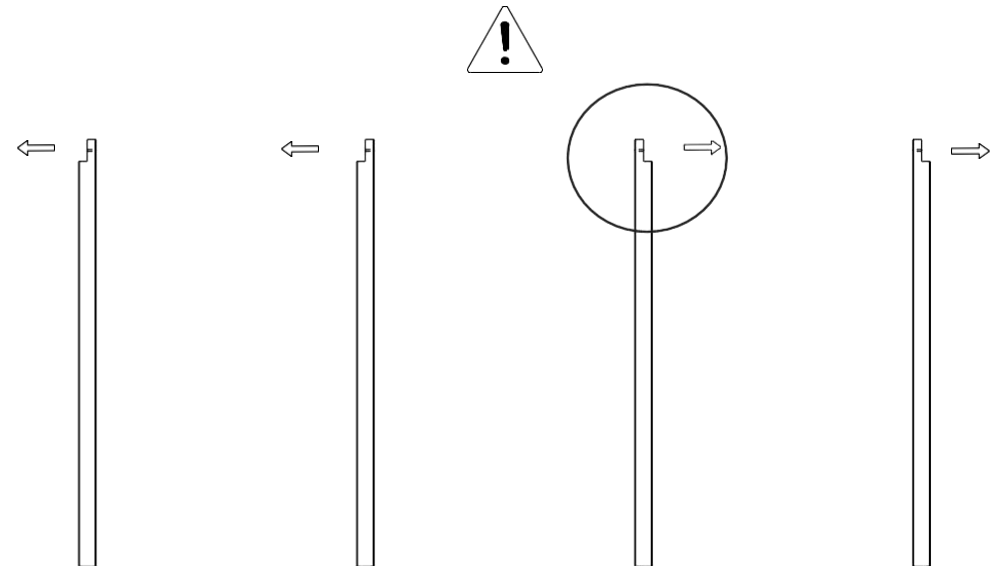
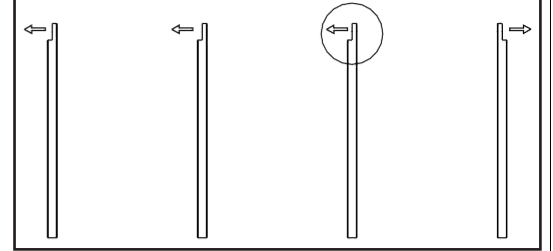

CONSTRUCTIE
CONSTRUCTION

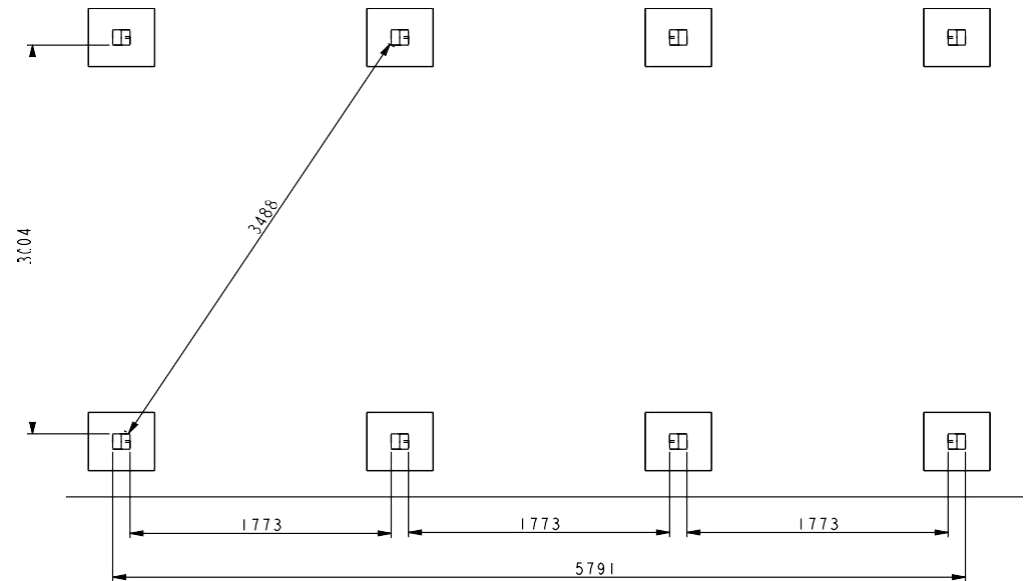
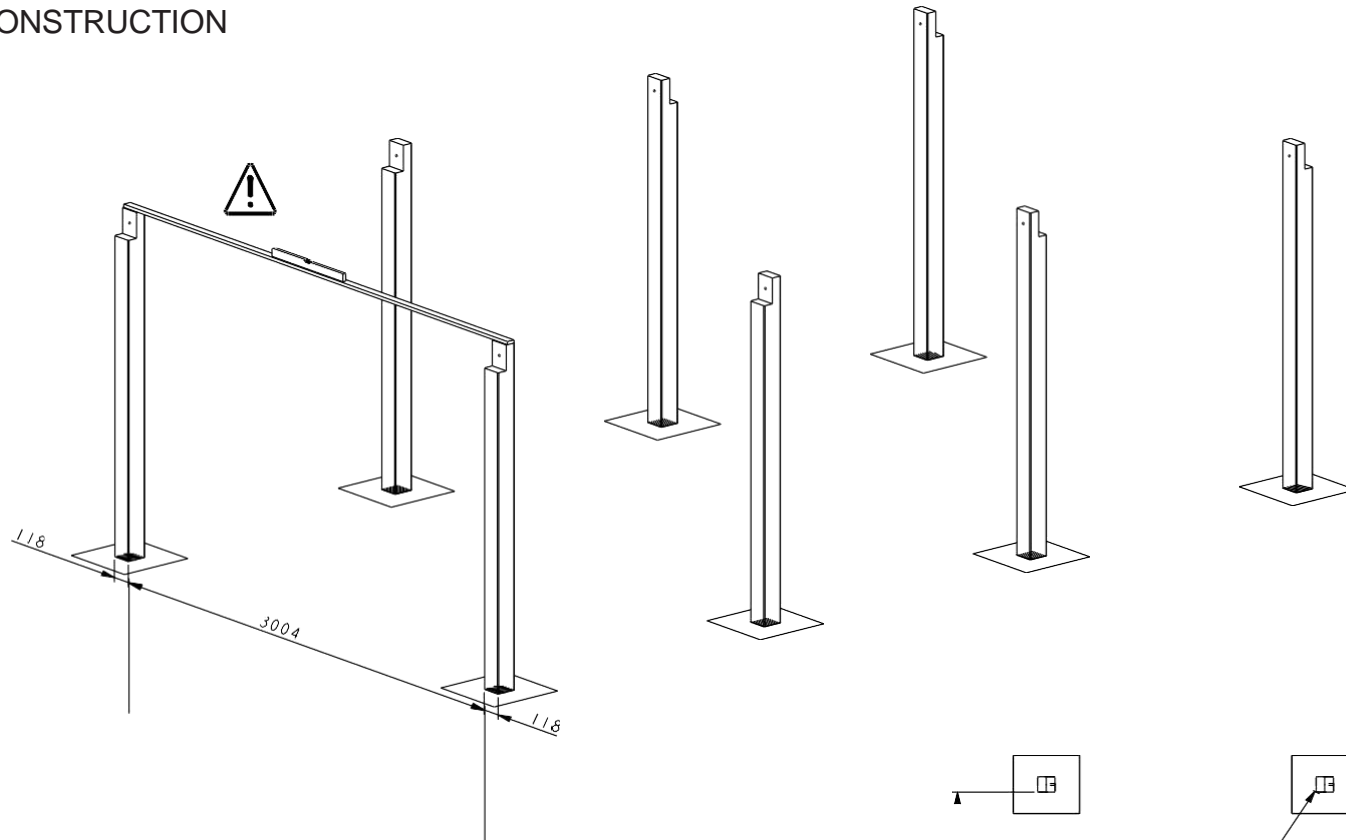

Palen	
118x118x3300	
KA.12	3X2
KA.13	4X2
KA.14	5X2
KA.15	6X2

MONTAGE liggers
MONTAGE traverses

VIEW D

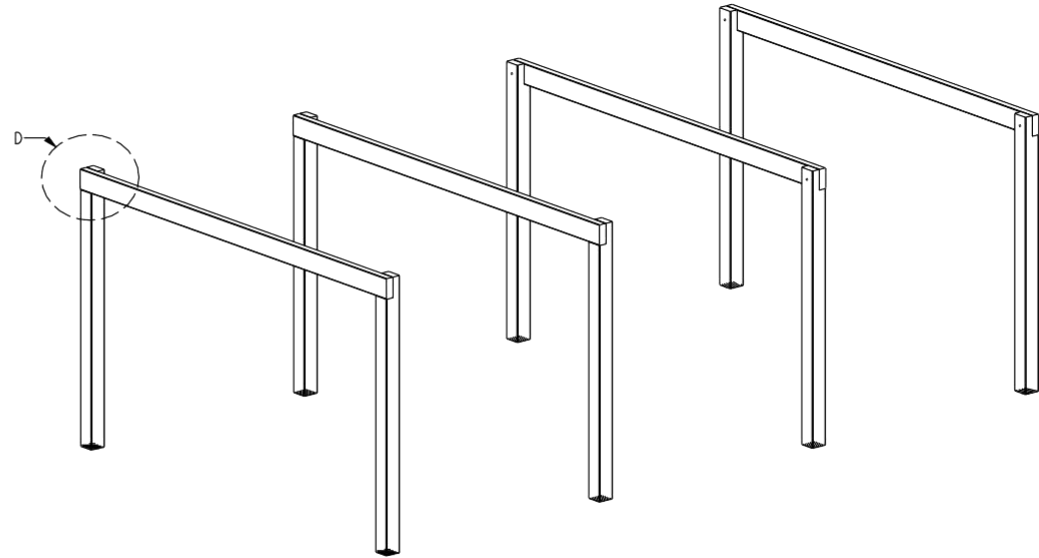
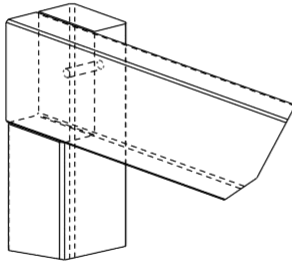

VIEW E

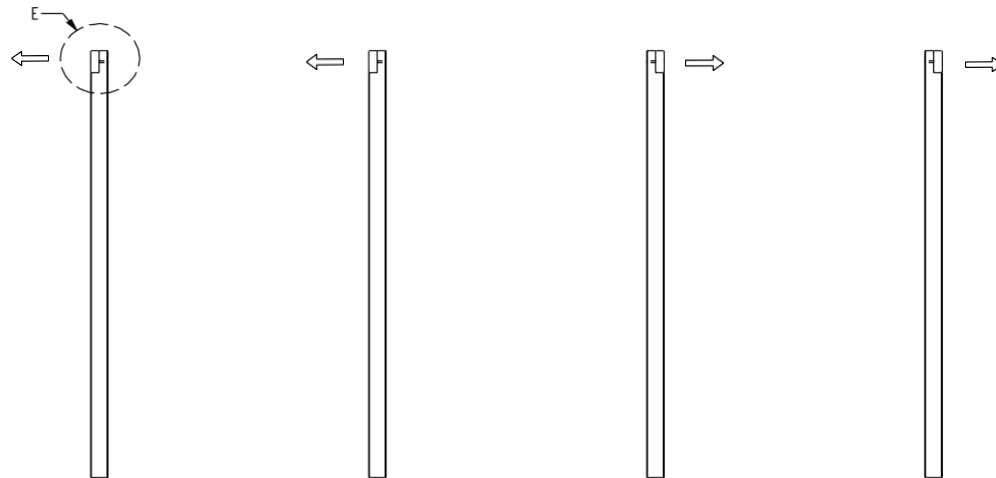
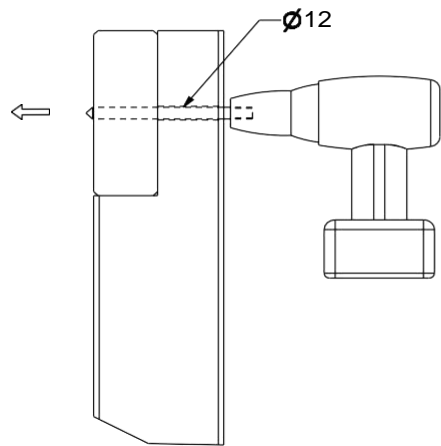

MONTAGE liggers
MONTAGE traverses

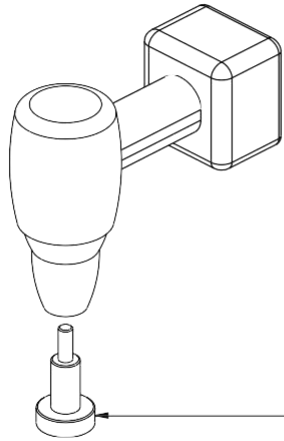

Meegeleverde forstnerboor $\varnothing 40$
Mèche à bois fourni $\varnothing 40$

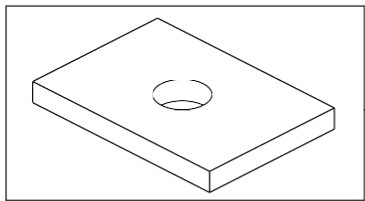
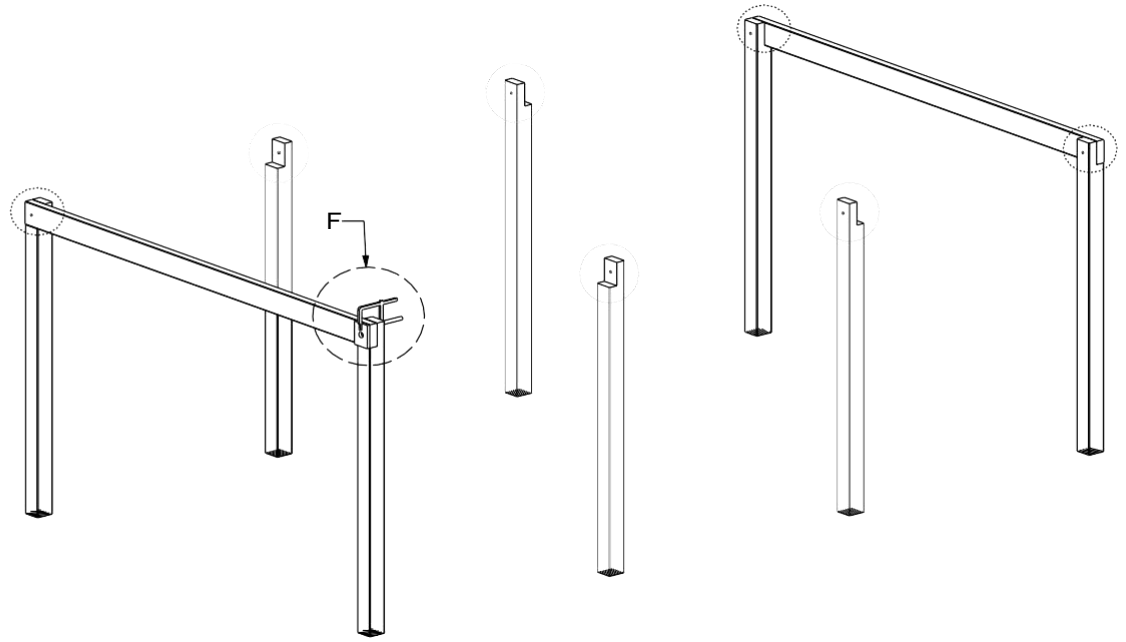

Niet meegeleverd
Non-fourni



VIEW F

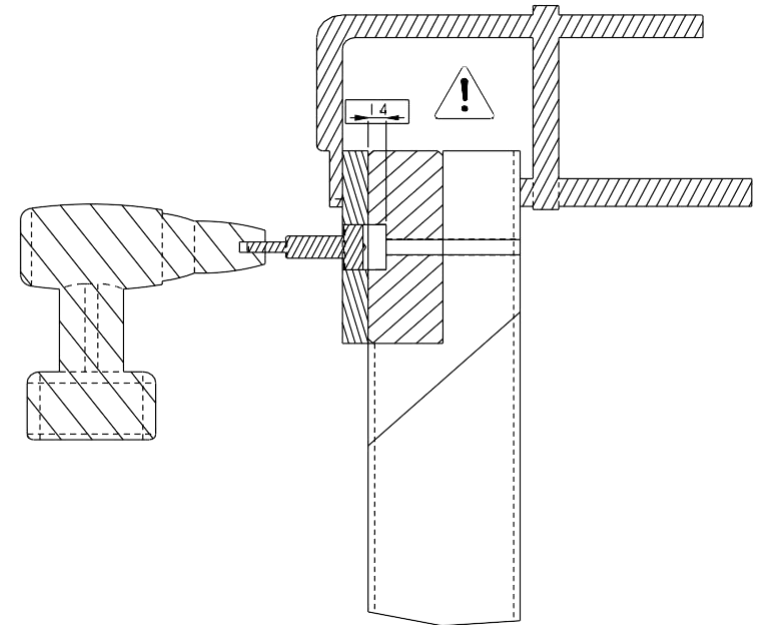
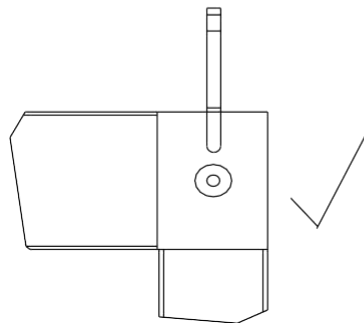
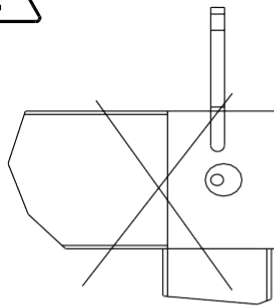
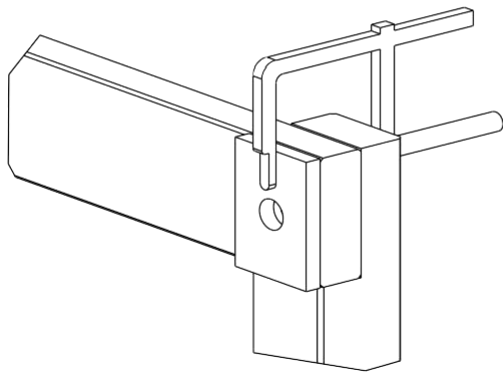

CONSTRUCTIE liggers
CONSTRUCTION traverses

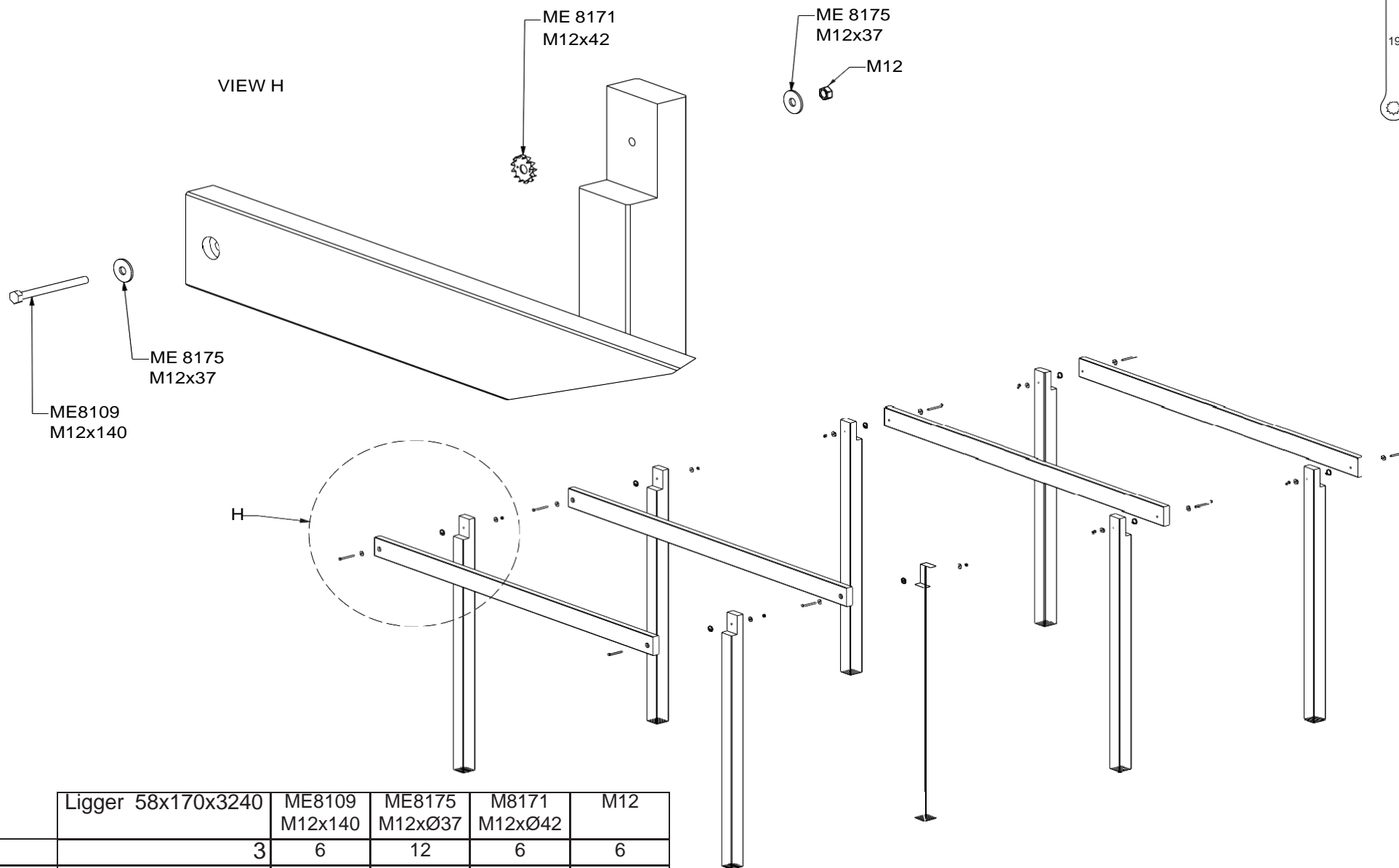

	Ligger 58x170x3240	ME8109 M12x140	ME8175 M12xØ37	M8171 M12xØ42	M12
KA.12	3	6	12	6	6
KA.13	4	8	16	8	8
KA.14	5	10	20	10	10
KA.15	6	12	24	12	12

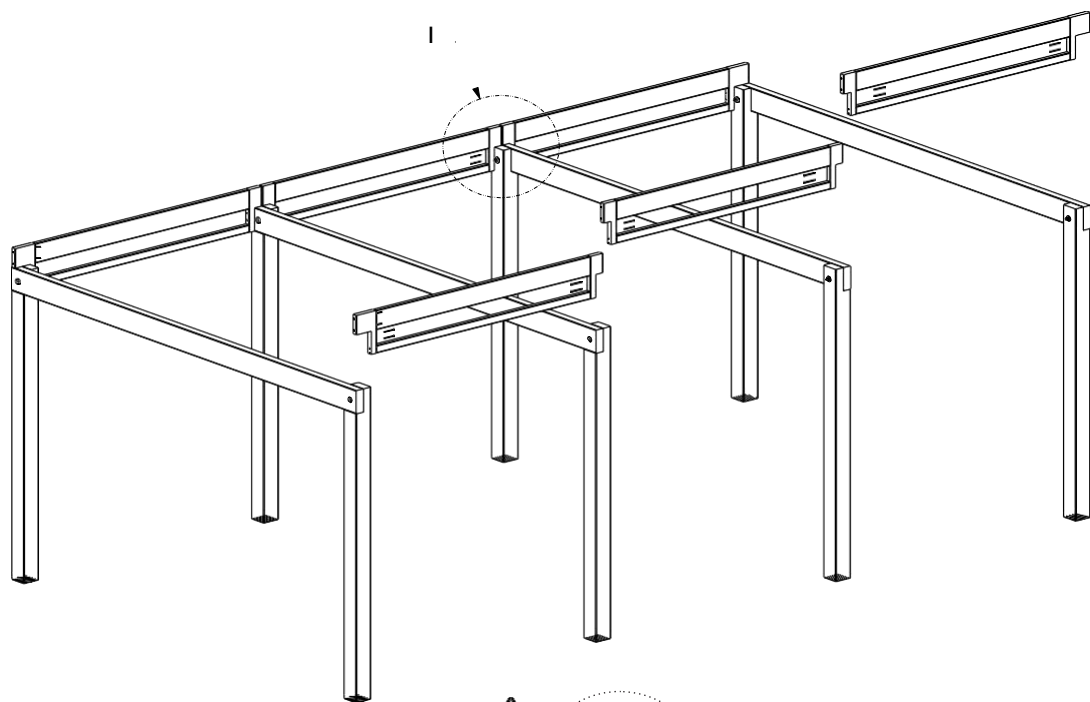

2x ME8420_5x80 A2

DETAIL I

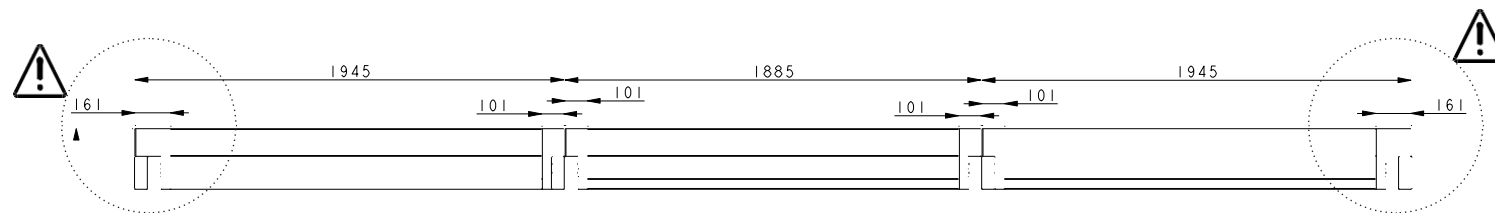
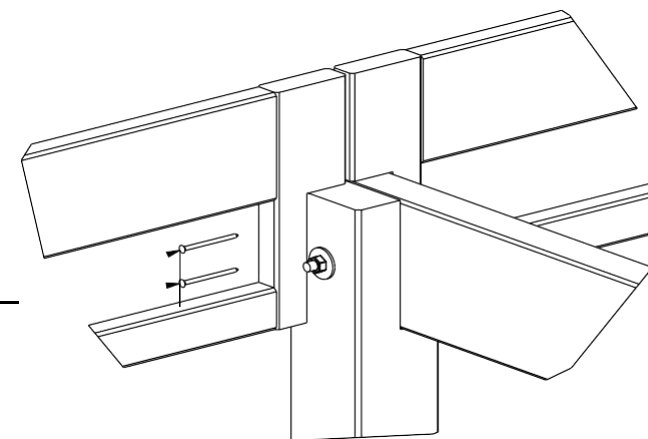

2422

	ME8420 5x80 A2
KA.12	16
KA.13	24
KA.14	32
KA.15	40



MONTAGE gout
MONTAGE gouttière

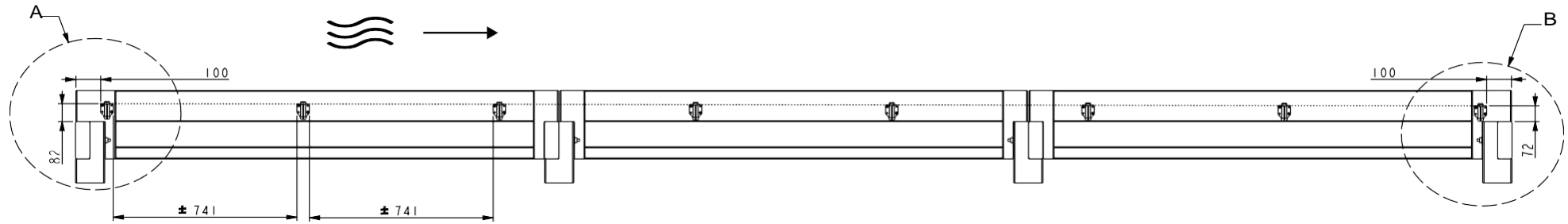
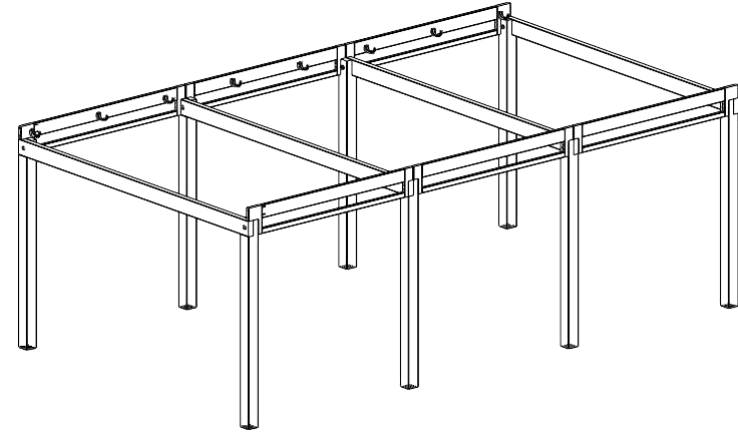
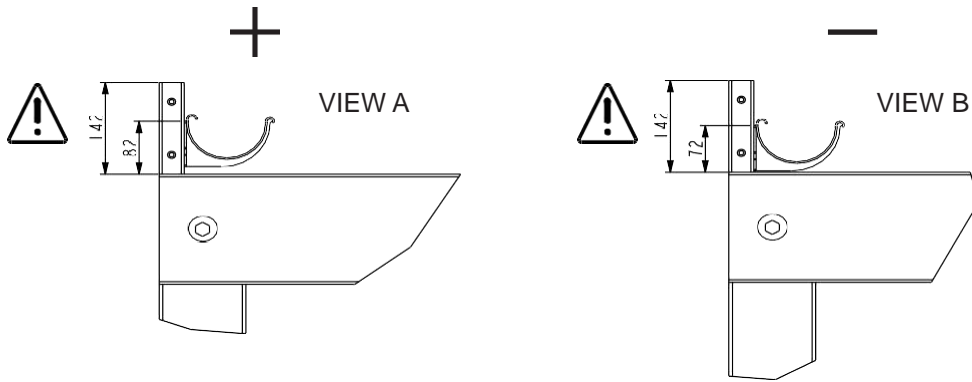

VIEW A

VIEW B

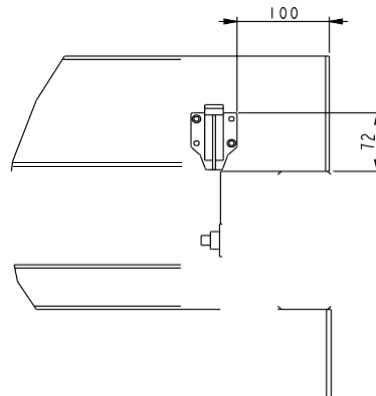
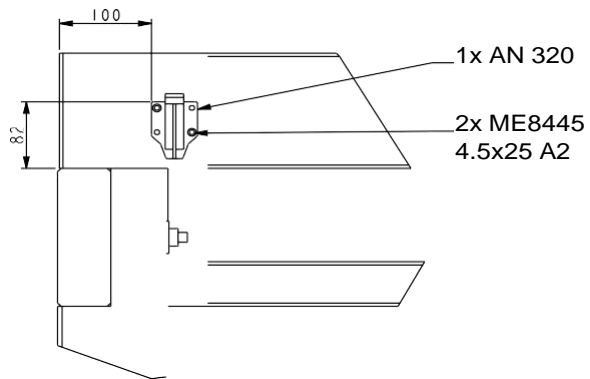

	AN320	ME8445 4,5 x 25 A2
KA.12	6	12
KA.13	8	16
KA.14	10	20
KA.15	13	26

MONTAGE daksparren
MONTAGE chevrons

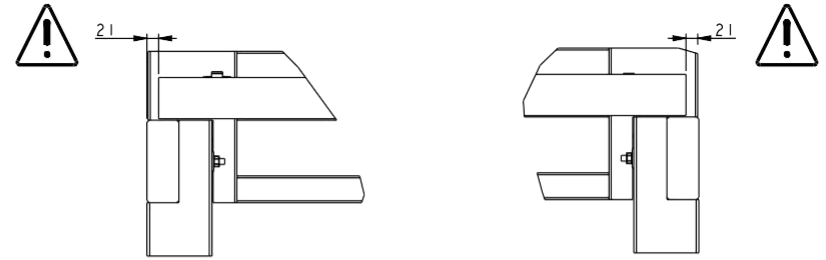
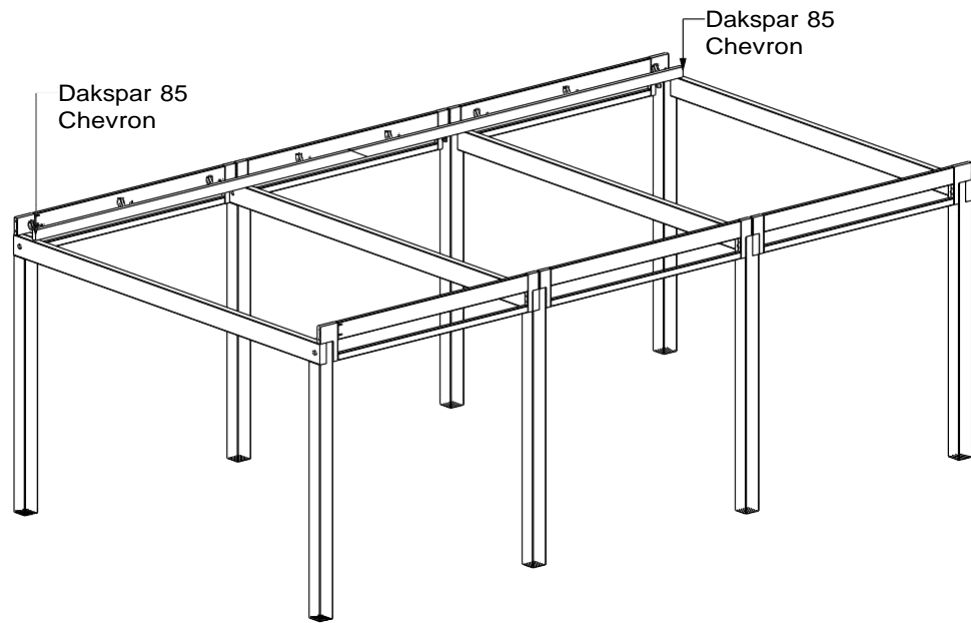

VIEW C

VIEW K

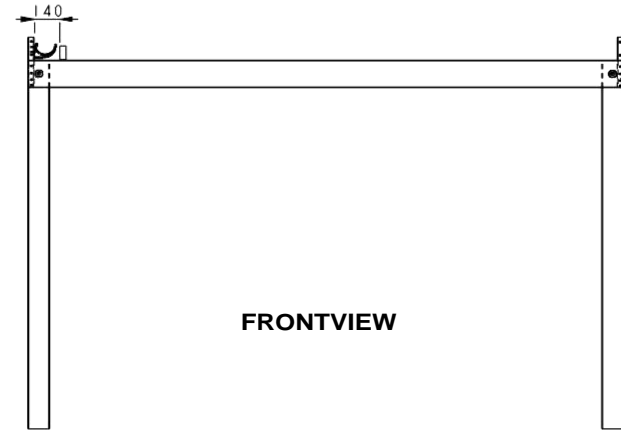
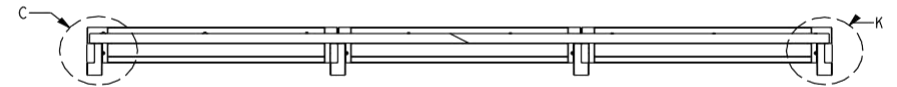

FRONTVIEW

 **TEKEN DE POSITIE VAN DE LIGGERS AF OP DE DAKSPAR
MARQUEZ LA POSITION DES TRAVERSES SUR LES CHEVRONS**

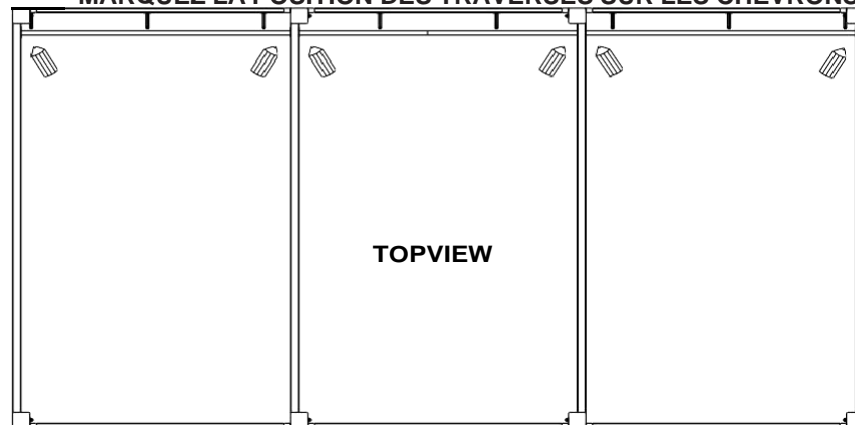

TOPVIEW

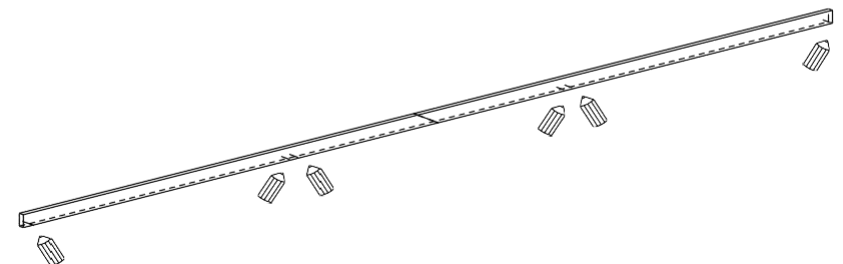

KA.12

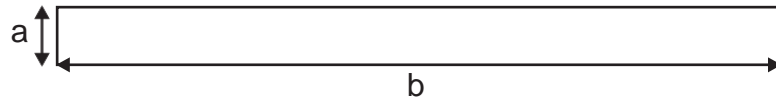

KA.13

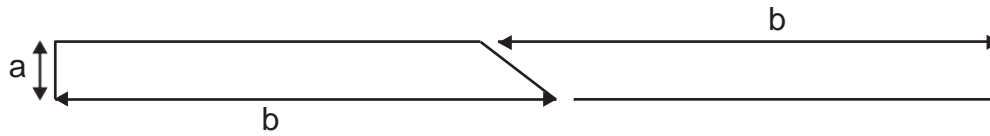

KA.14

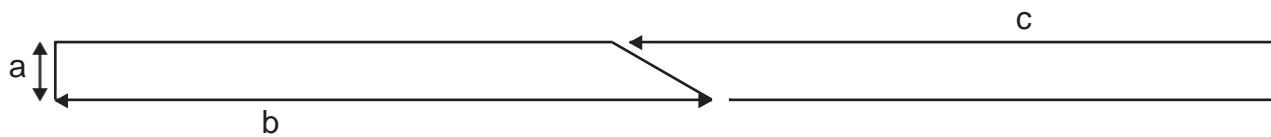

KA.15



		KA.12	KA.13	KA.14		KA.15	
		1xb	2xb	1xb	1xc	2xb	1xd
a	85	3858	2948	4156	3631	2948	3929
	93	3858	2955	4156	3645	2955	3943
	105	3858	2965	4156	3665	2965	3963
	117	3858	2976	4156	3686	2976	3984
	129	3858	2986	4156	3707	2986	4007

— Teken de positie van de liggers af op de daksparren.
 Marquez la position des traverses sur les chevrons.

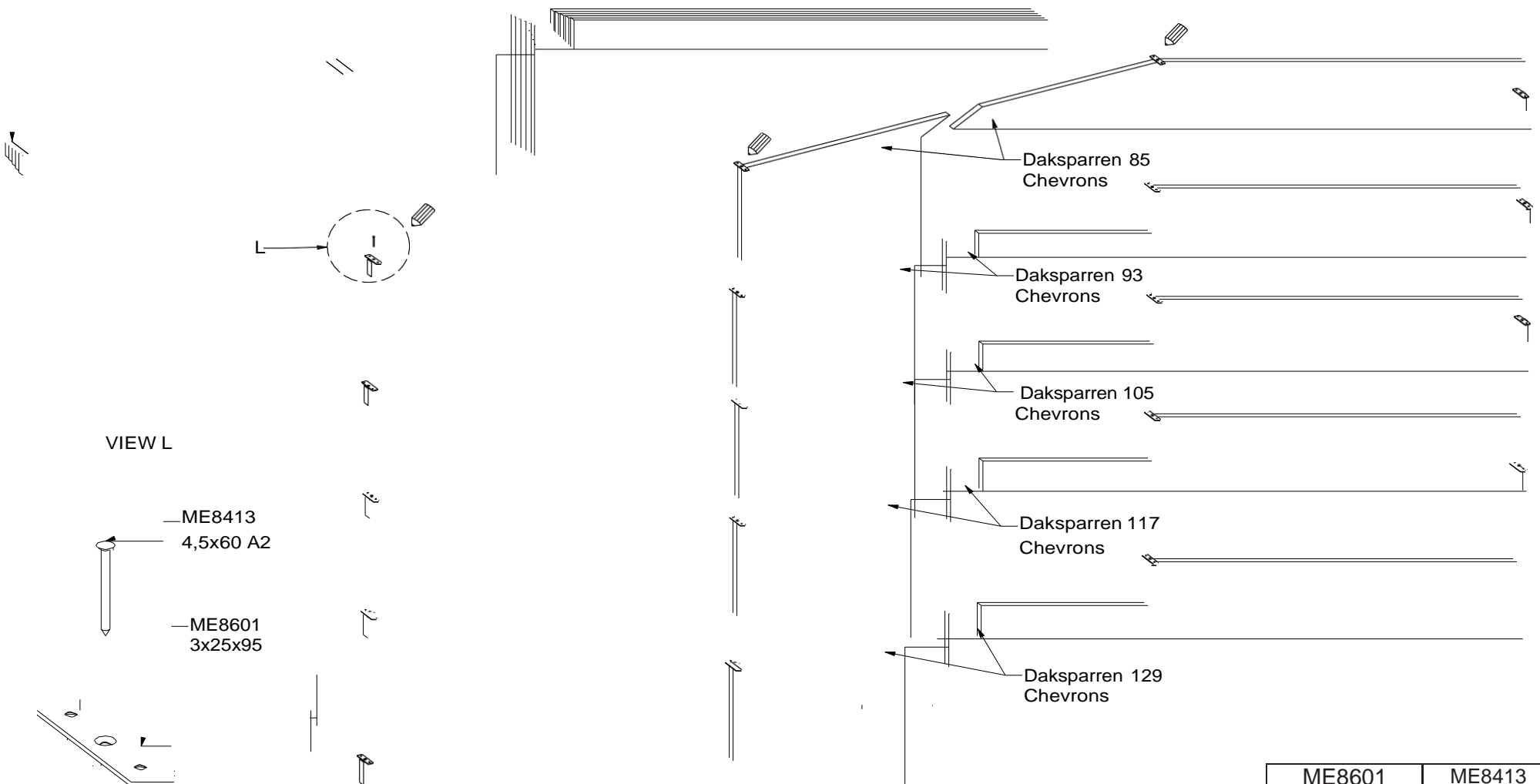

VIEW L

—ME8413
4,5x60 A2

—ME8601
3x25x95

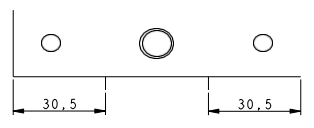
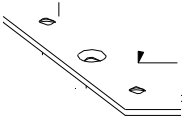

	ME8601 3x25x95	ME8413 4,5x60 A2
KA.12	15	15
KA.13	20	20
KA.14	25	25
KA.15	30	30

MONTAGE daksparren
MONTAGE chevrons

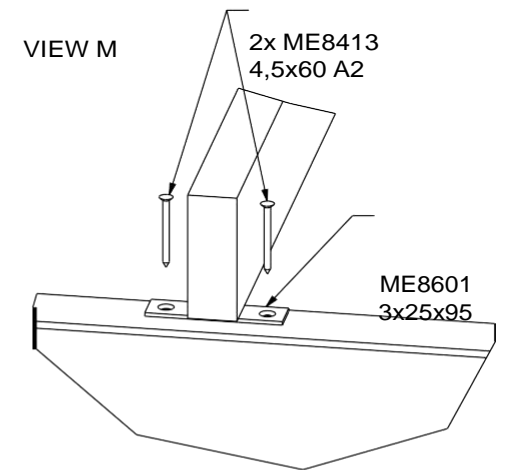
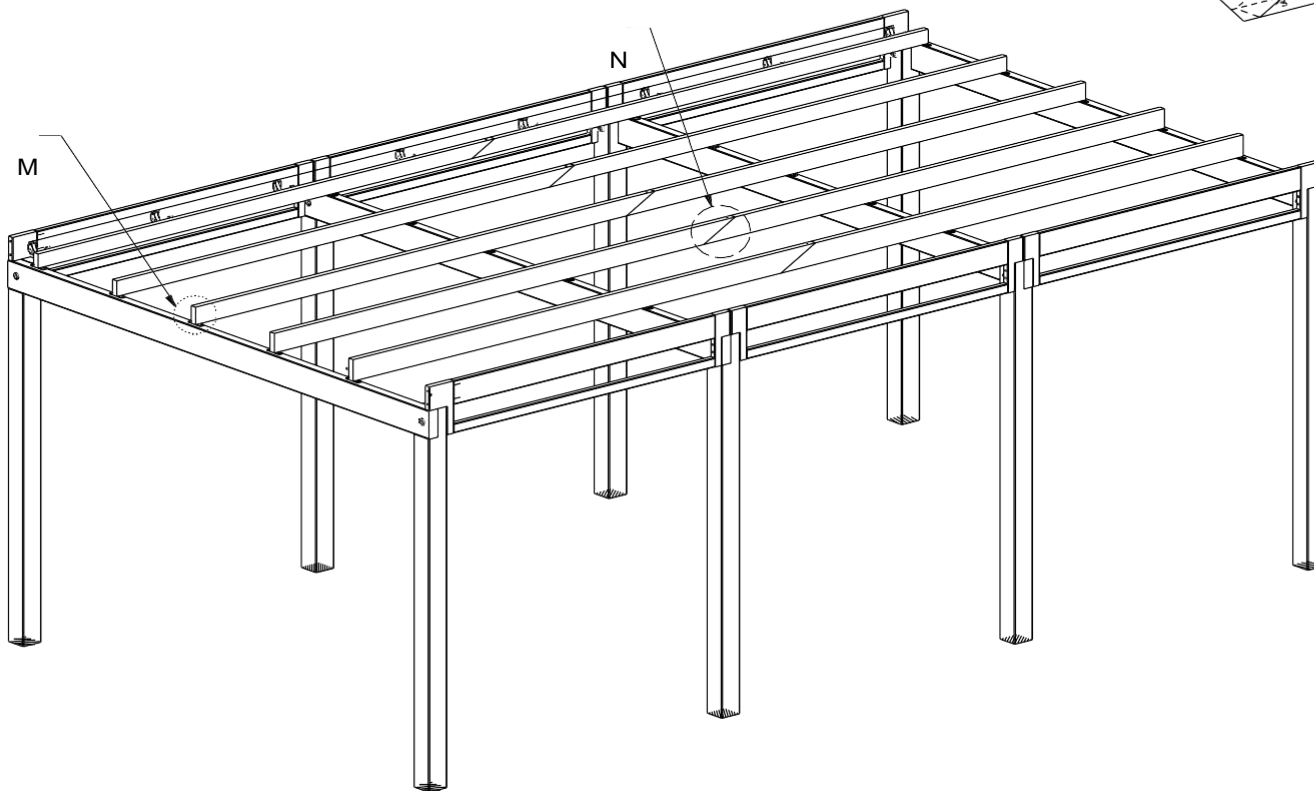
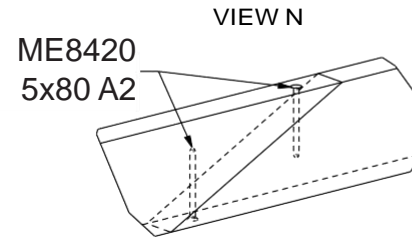
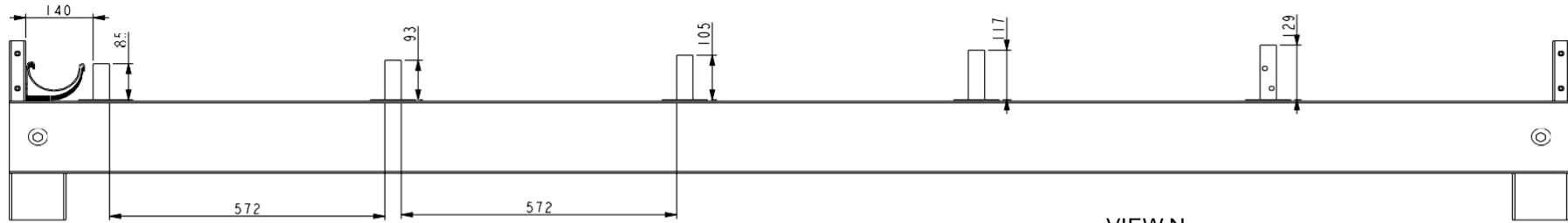

KA.12		
KA.13		

15

ME8413 4,5x60 A2	ME8420 5x80 A2
30	0
40	10
50	10
60	20

MONTAGE lat voor dakafwerking
MONTAGE support de rive

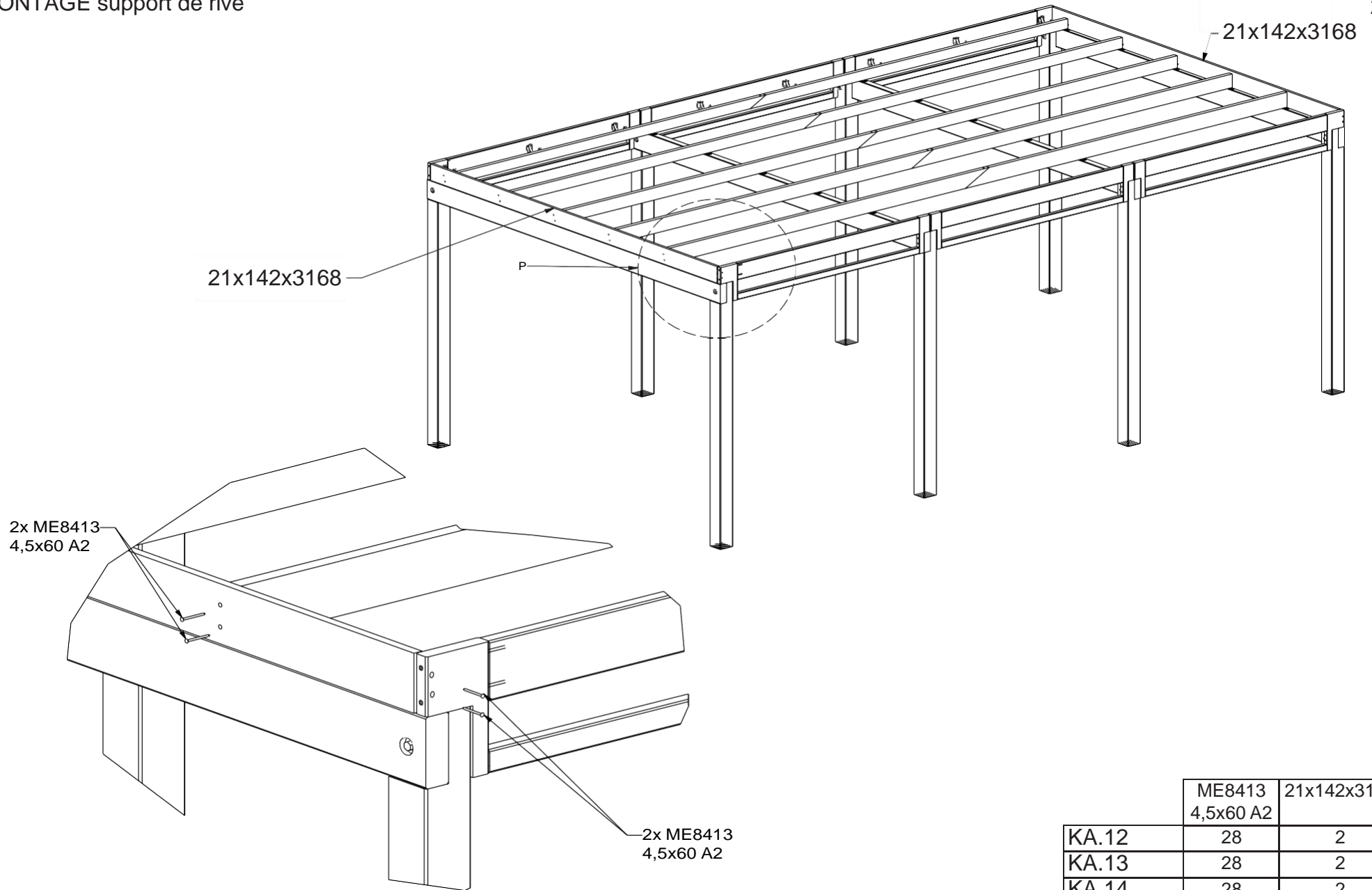

	ME8413 4,5x60 A2	21x142x3168
KA.12	28	2
KA.13	28	2
KA.14	28	2
KA.15	28	2

GOOT SAMENSTELLING
ASSEMBLAGE gouttière

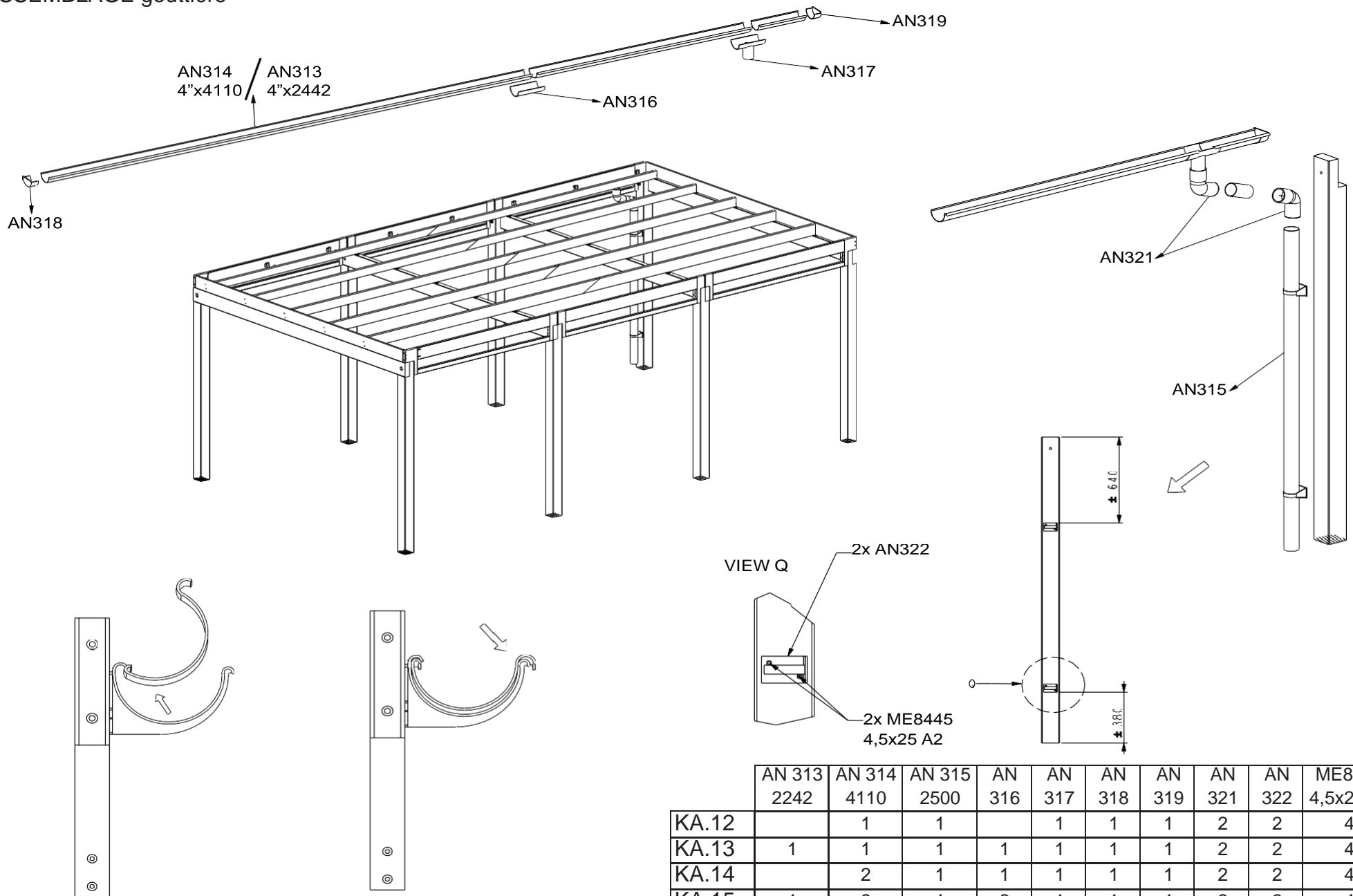

	AN 313 2242	AN 314 4110	AN 315 2500	AN 316	AN 317	AN 318	AN 319	AN 321	AN 322	ME8445 4,5x25 A2
KA.12		1	1		1	1	1	2	2	4
KA.13	1	1	1	1	1	1	1	2	2	4
KA.14		2	1	1	1	1	1	2	2	4
KA.15	1	2	1	2	1	1	1	2	2	4

BEKLEDING
REVÊTEMENT

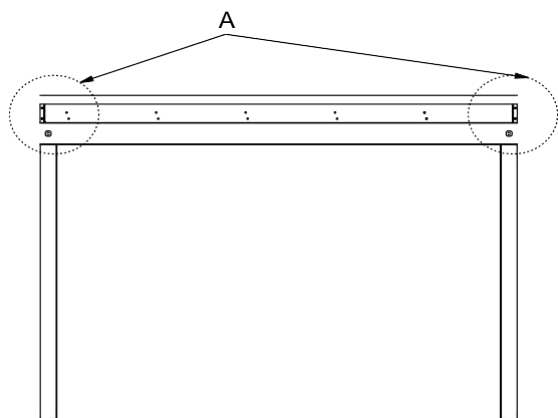
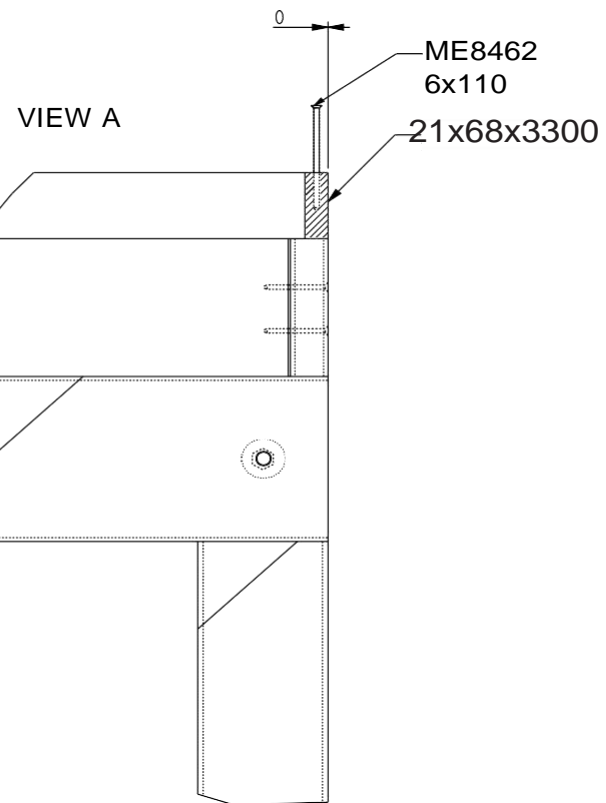
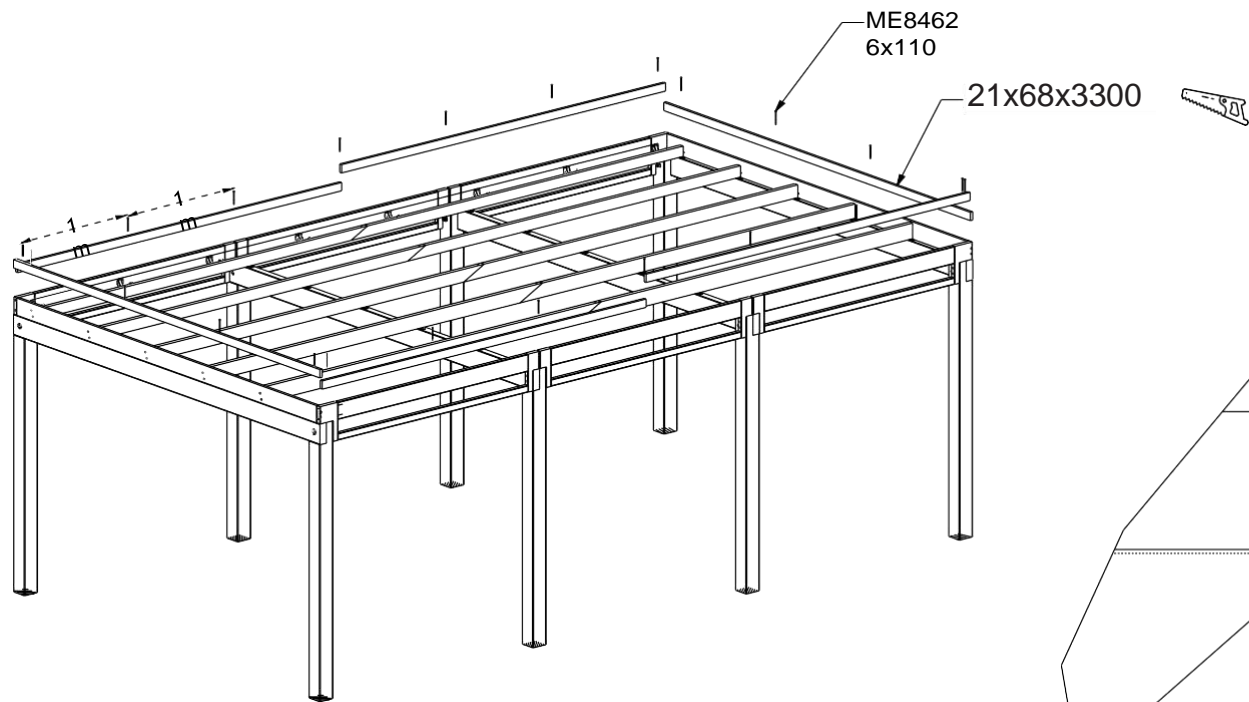

	21X68X3300	ME8462 6x110
KA.12	5	16
KA.13	6	20
KA.14	7	24
KA.15	8	27

BEKLEDING
REVÊTEMENT

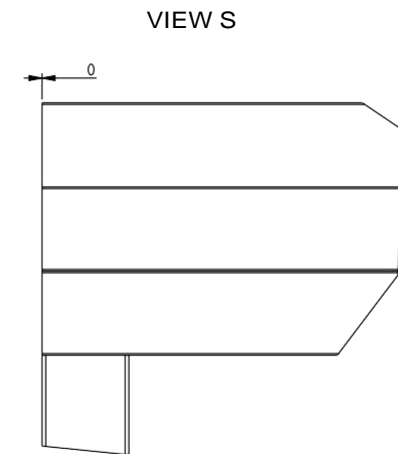
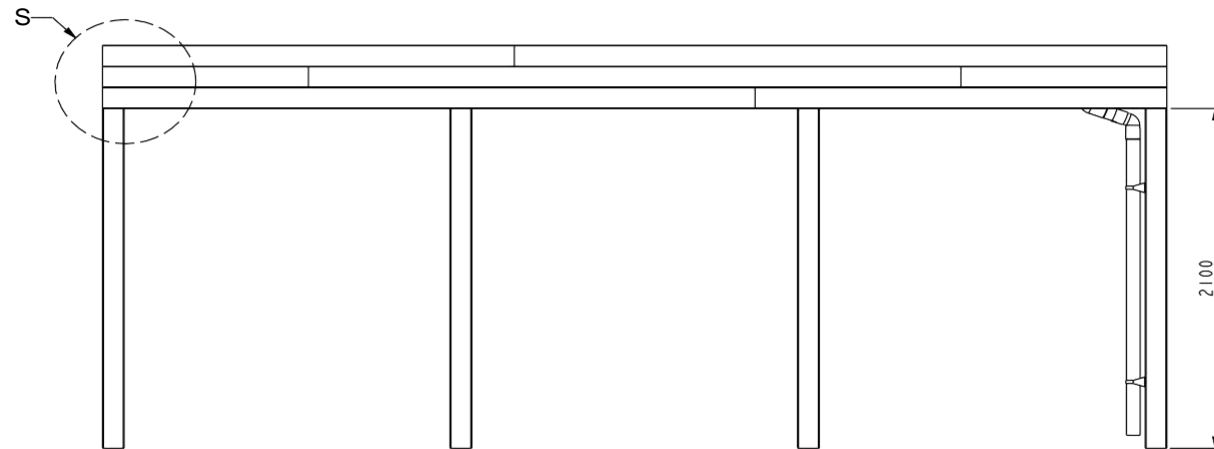
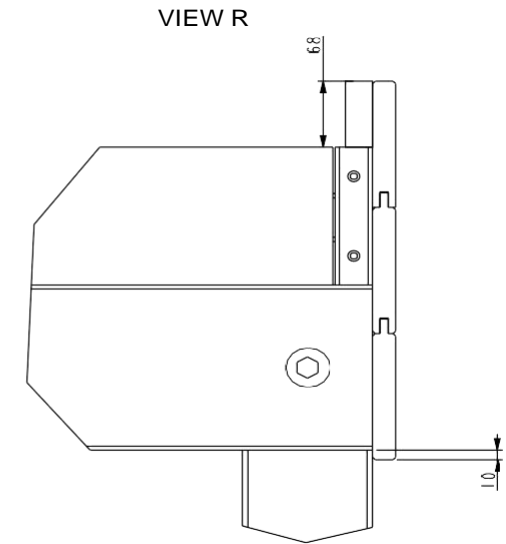
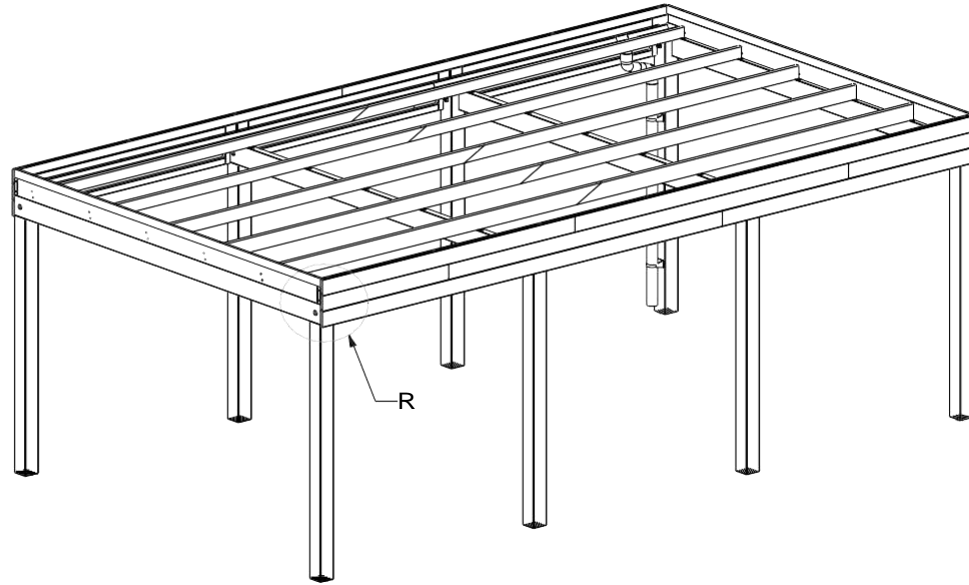

BEKLEDING
REVÊTEMENT

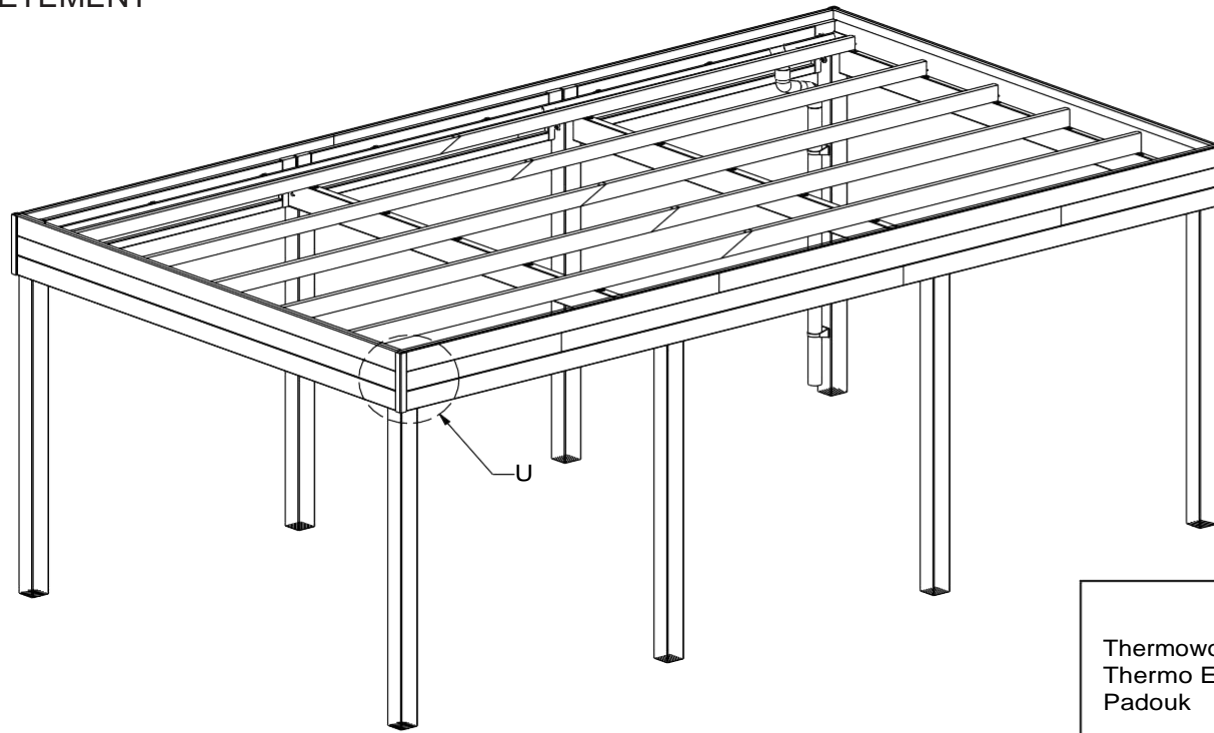

VIEW U

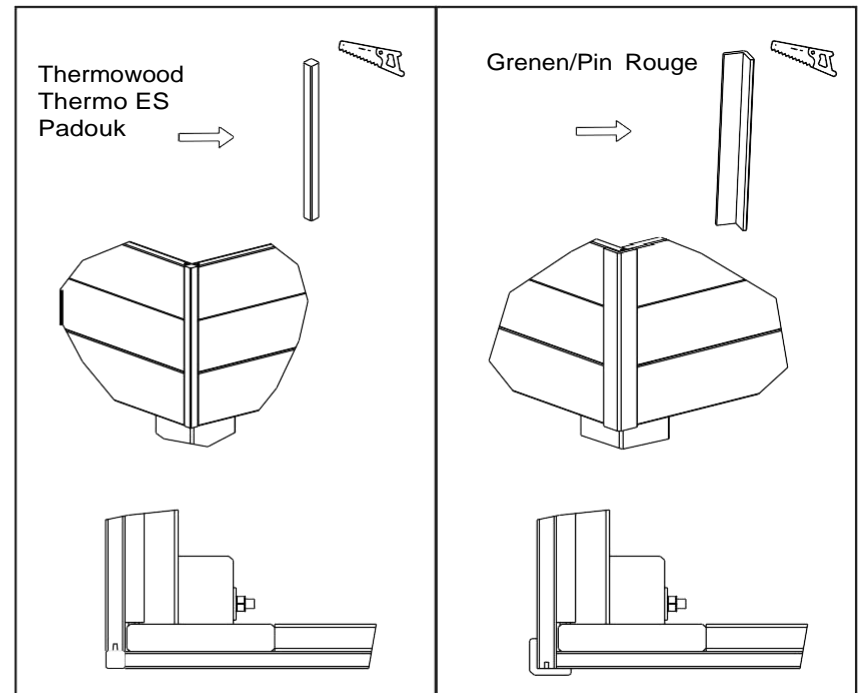
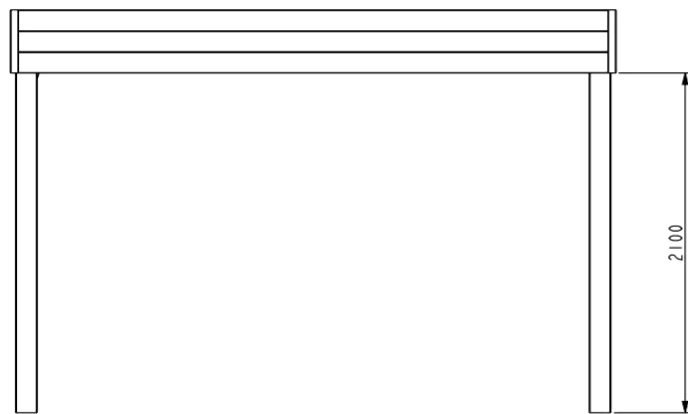
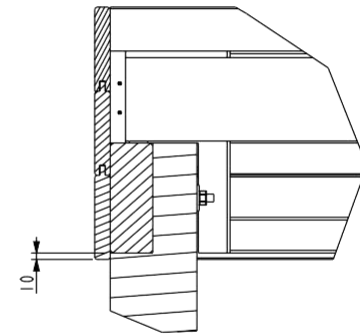

BUTYLTAPE

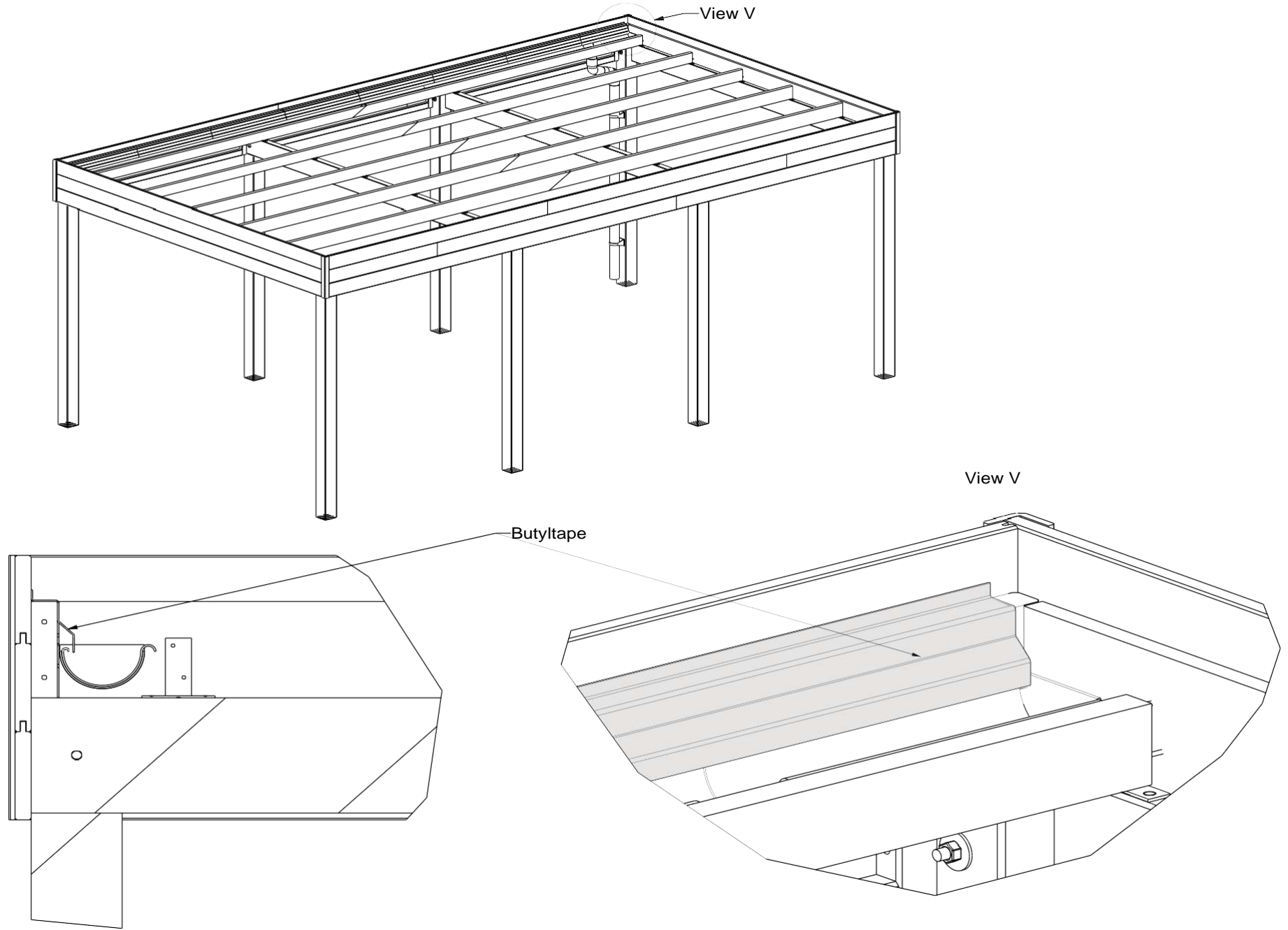

POLYCARBONATE



VIEW Y

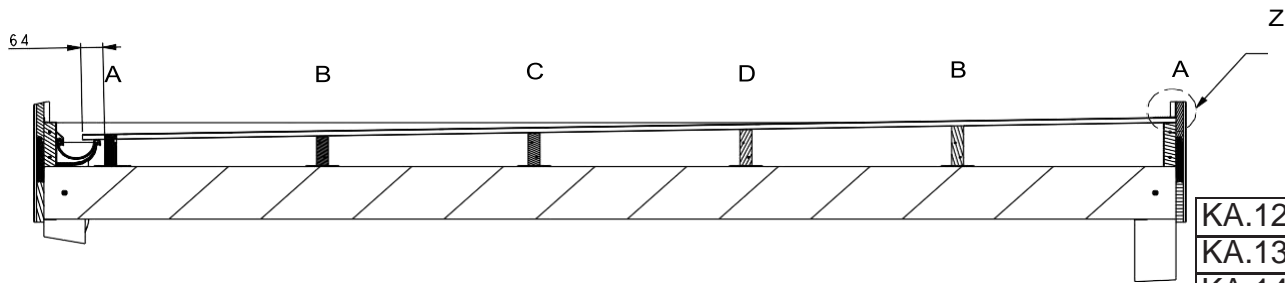
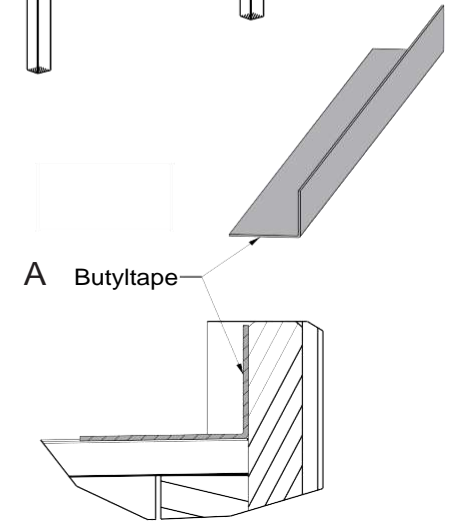
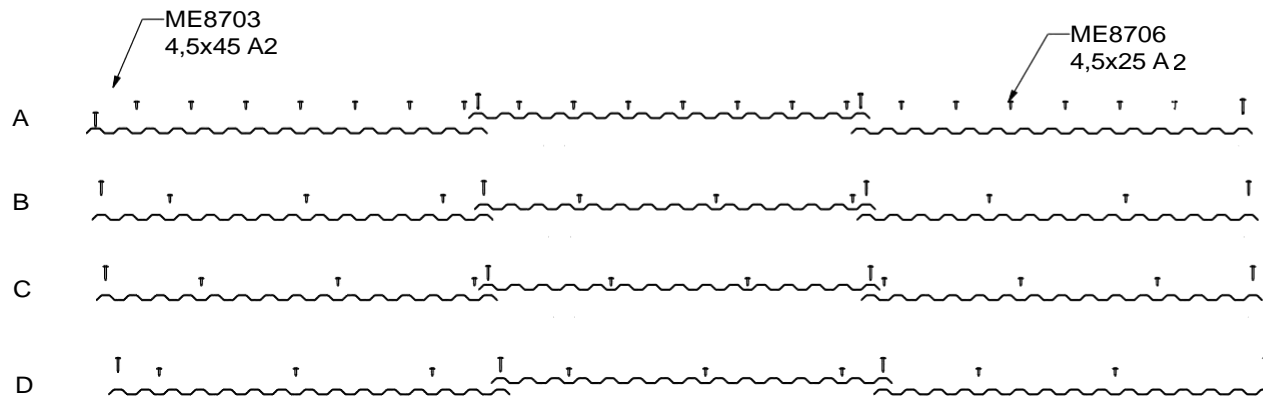
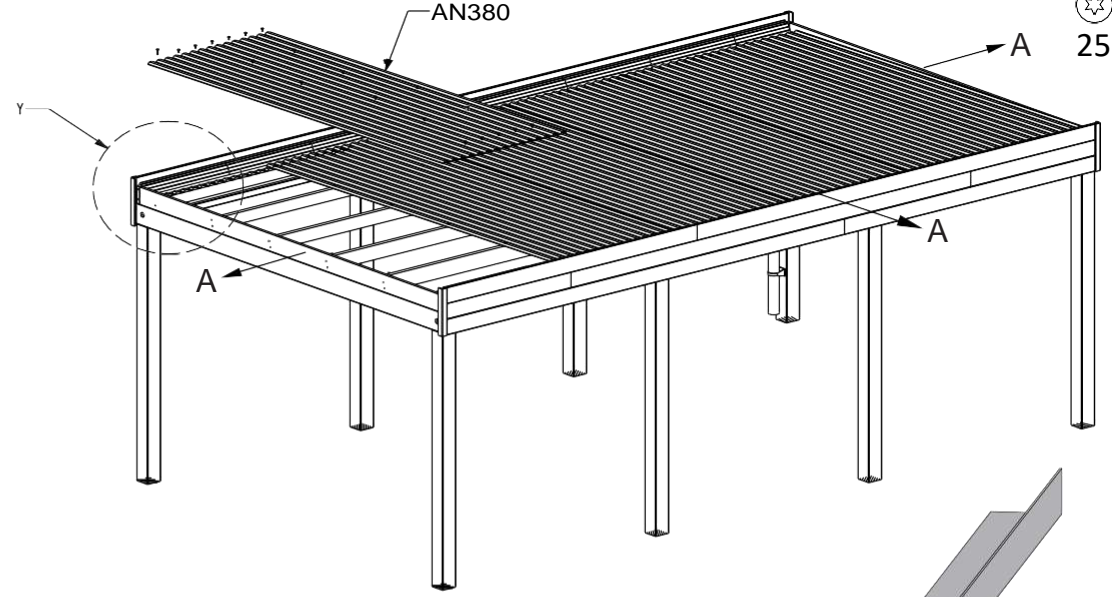
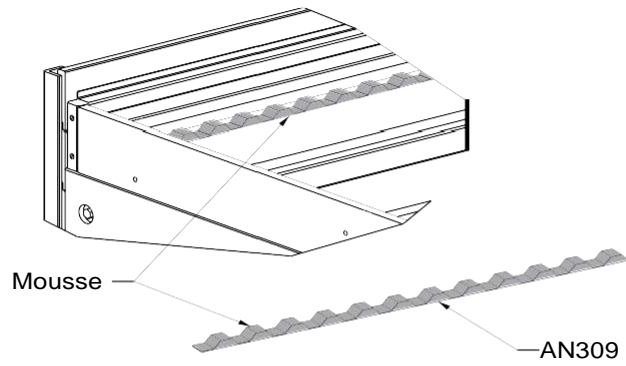

	AN309 24x30x910	AN380 1090x3130	ME8703 4,5x45 A2	ME8706 4,5x25 A2	Butyltape 10m
KA.12	5	4	32	70	1x
KA.13	7	6	47	104	2x
KA.14	9	8	63	138	3x
KA.15	11	10	78	171	3x

STAALDAK
BAC ACIER

VIEW Z

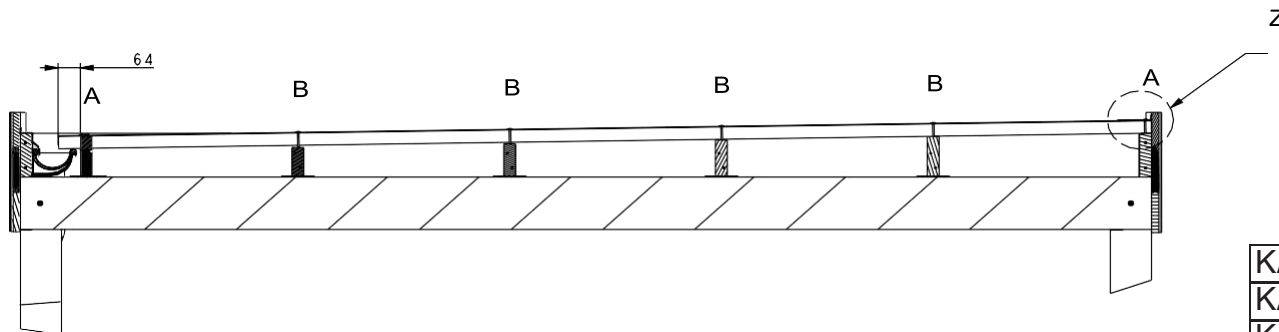
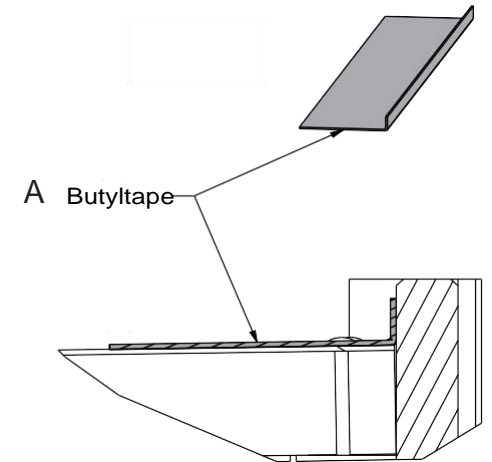
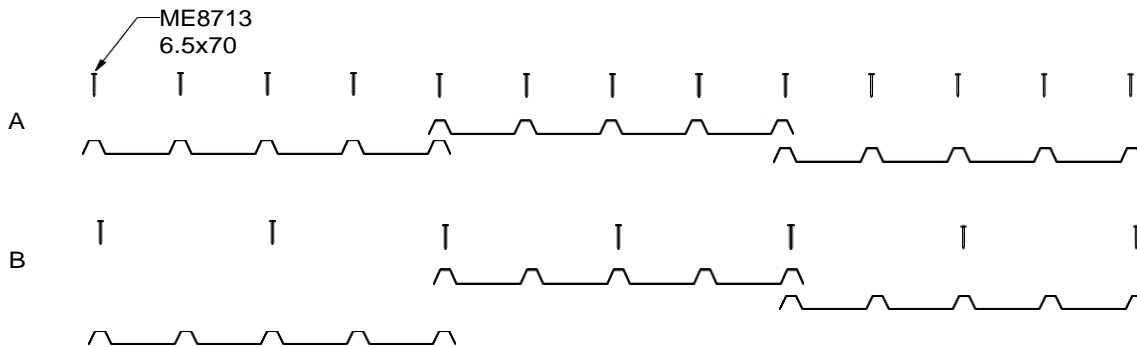
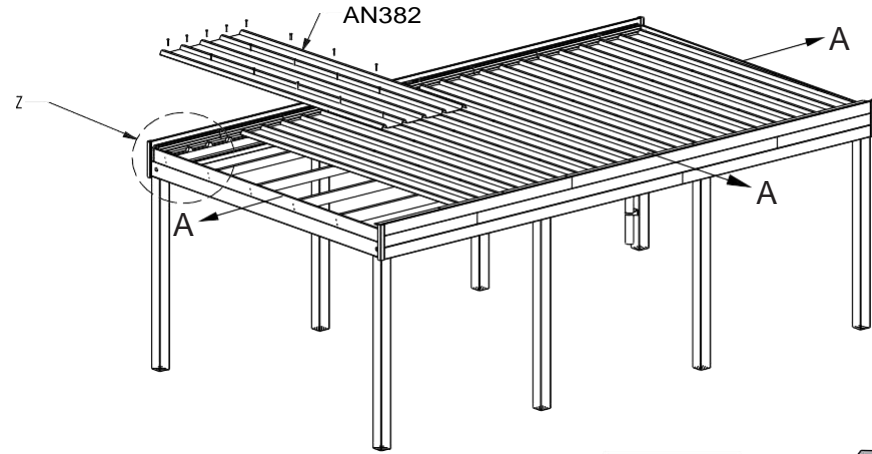
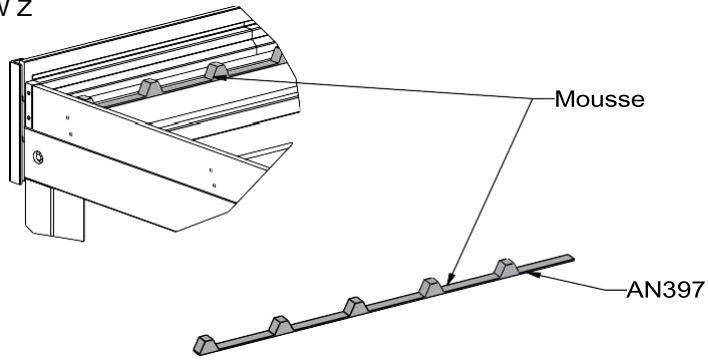

	AN397 30x41x1000	AN382 1050x3130	ME8713 6.5x70	Butyltape 10m
KA.12	4	4	83	1x
KA.13	6	6	123	2x
KA.14	8	8	162	3x
KA.15	10	10	202	3x

STAALDAK BAC ACIER

Aanbrengen vernis

Om te vermijden dat water omhoog kruipt door de capillariteit, is het noodzakelijk de anti-condens film te neutraliseren met een vernis en toe te passen op volgende zones.

A = De zone onderaan het dak, waar de plaat over de dakgoot komt.

B = De zone waar de plaat overlapt op de ander plaat.

De breedte die met het vernis moet worden geneutraliseerd moet minimaal **200mm** zijn.

TIP !

Om de vernis goed te kunnen aanbrengen, dient de plaat te worden platgelegd. De neutralisatie gebeurt door de vernis zorgvuldig aan te brengen tot verzadiging van de anti-condensatiefilm.

Application du vernis

Pour éviter que l'eau ne remonte par capillarité, il est nécessaire de neutraliser le film anti-condensation avec un vernis et de l'appliquer sur les zones suivantes.

A = La zone au bas du toit, où la tôle vient sur la gouttière.

B = La zone où la tôle se superpose à l'autre tôle.

La largeur à neutraliser avec le vernis doit être d'au moins **200mm**.

CONSEIL !

Pour appliquer correctement le vernis, la feuille doit être posée à plat. La neutralisation se fait en appliquant soigneusement le vernis jusqu'à saturation du film anti-condensation.

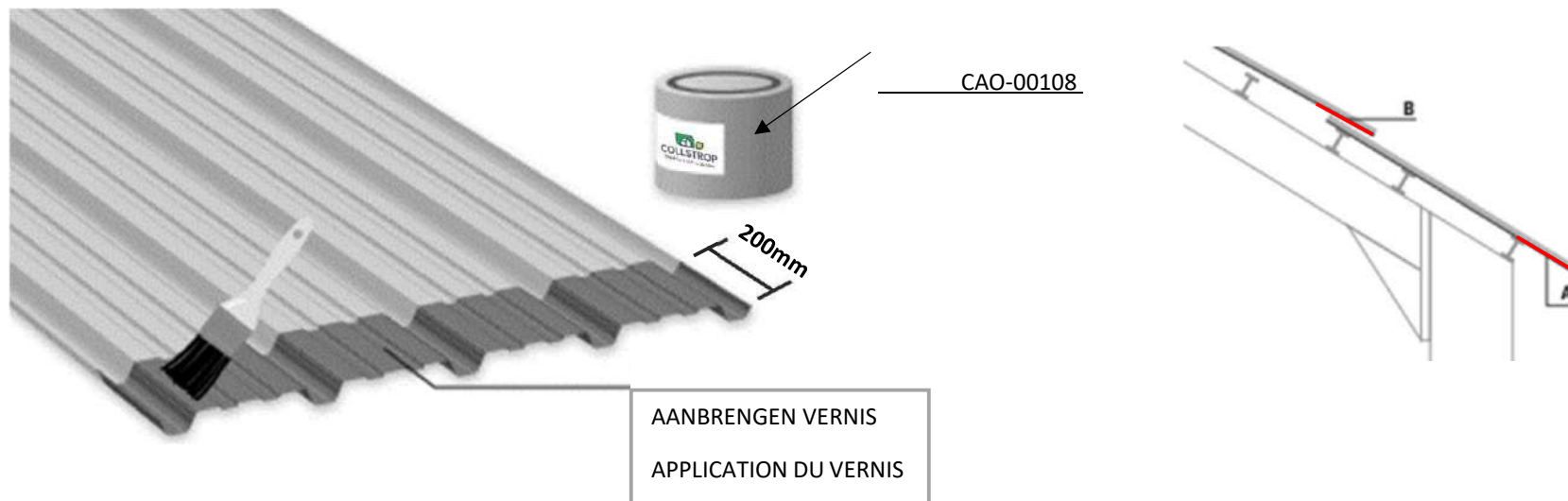

EPDM 1

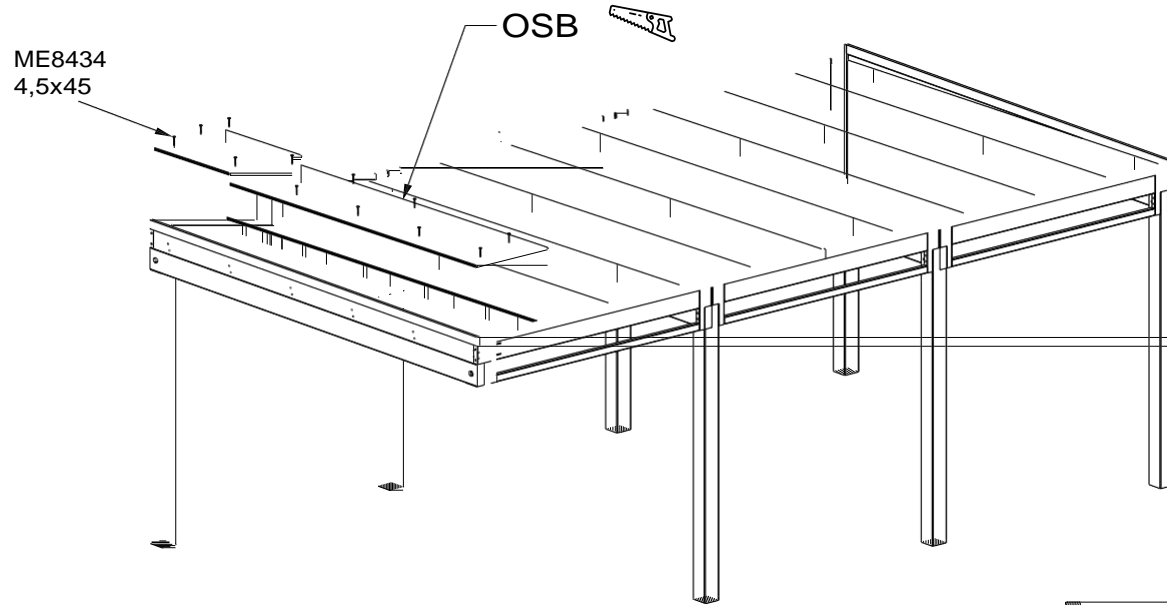

OSB

A - A1

C

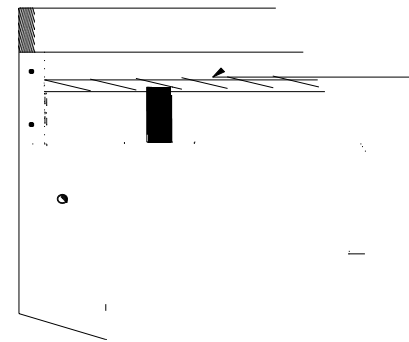
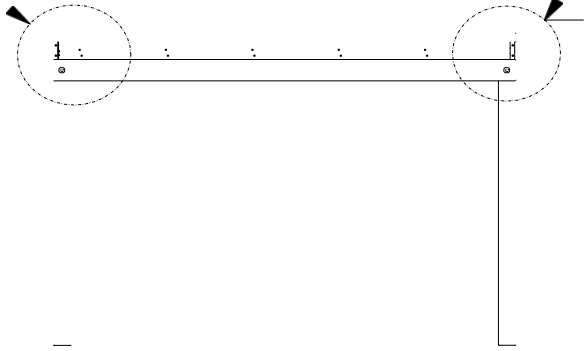

VIEW A - A1

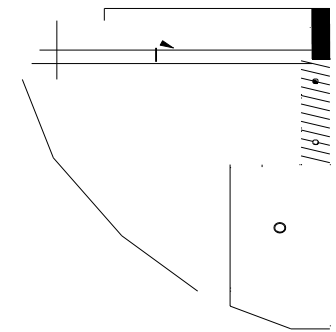

VIEW C

	OSB 18x60x2440	ME8434 4,5x45
KA.12	10	100
KA.13	14	140
KA.14	18	180
KA.15	22	220

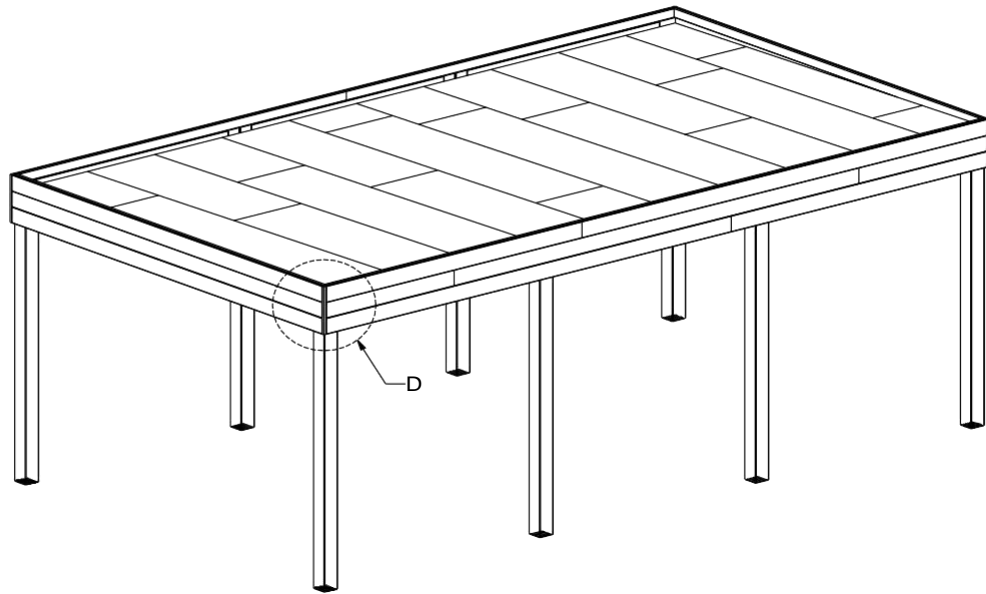

VIEW D

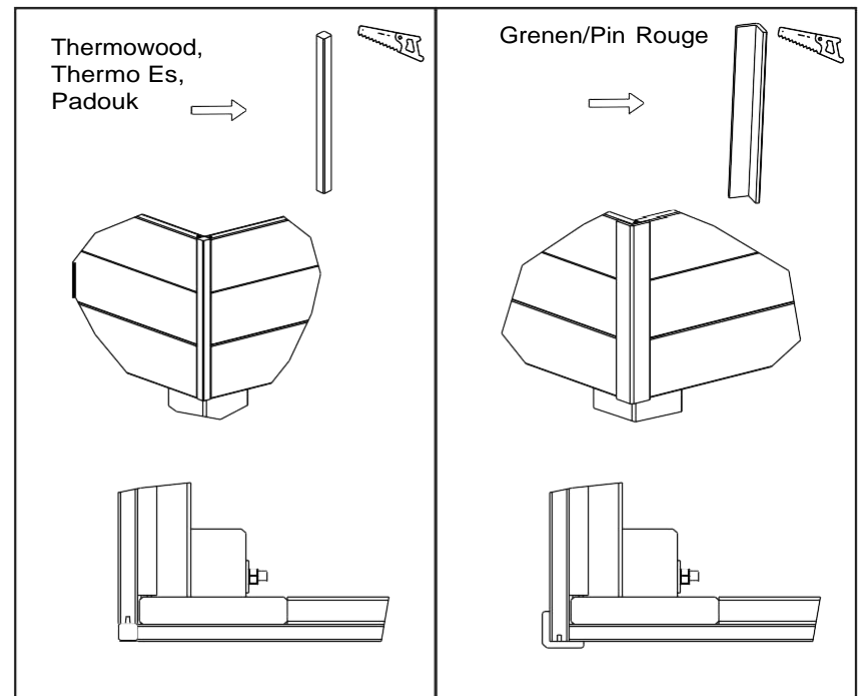
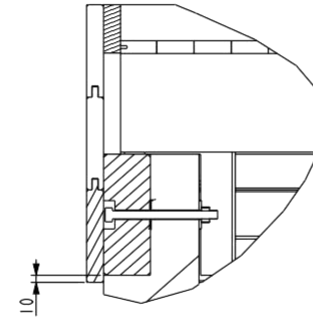

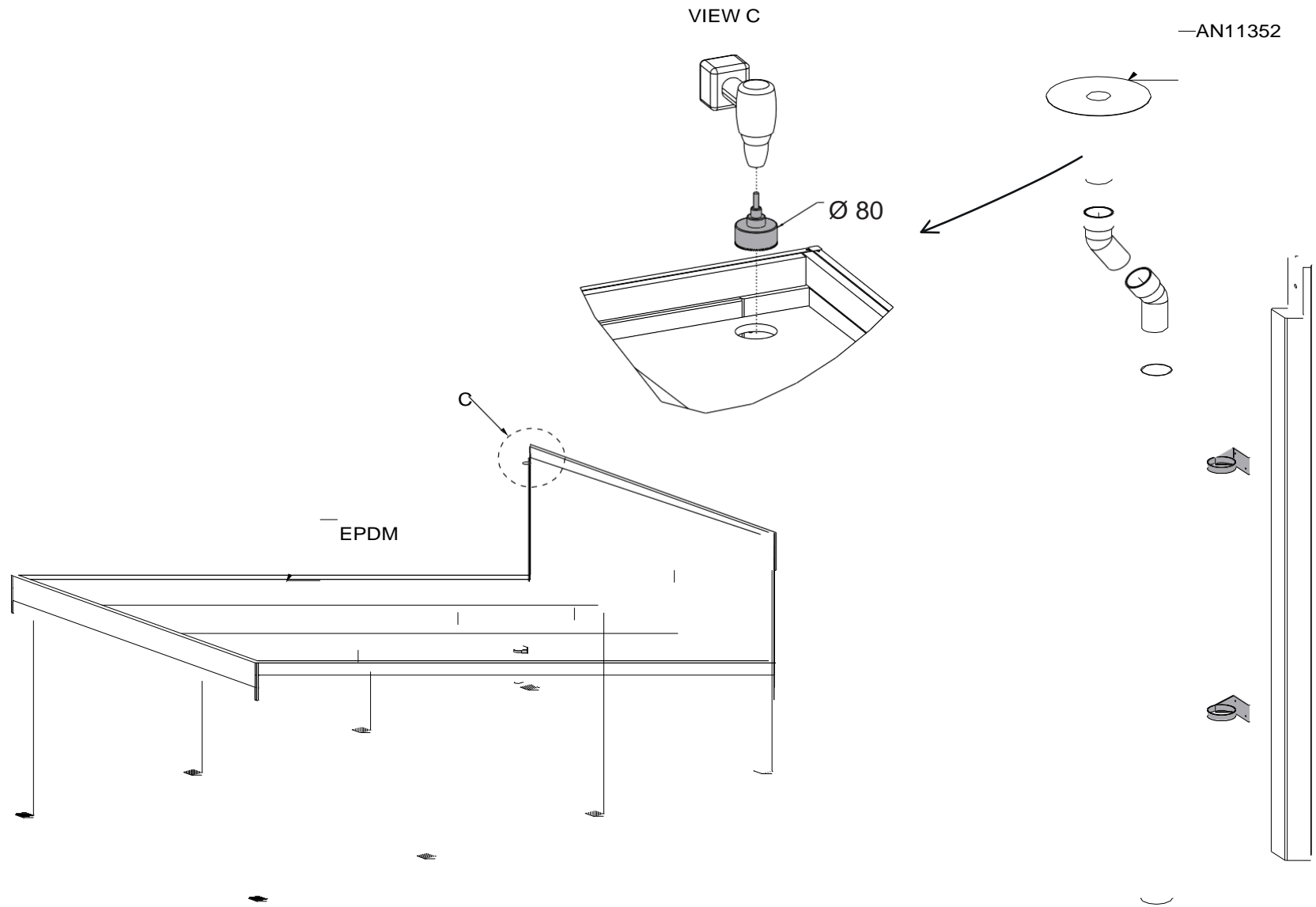

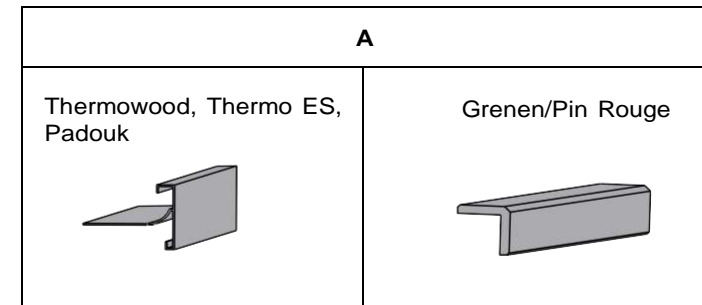
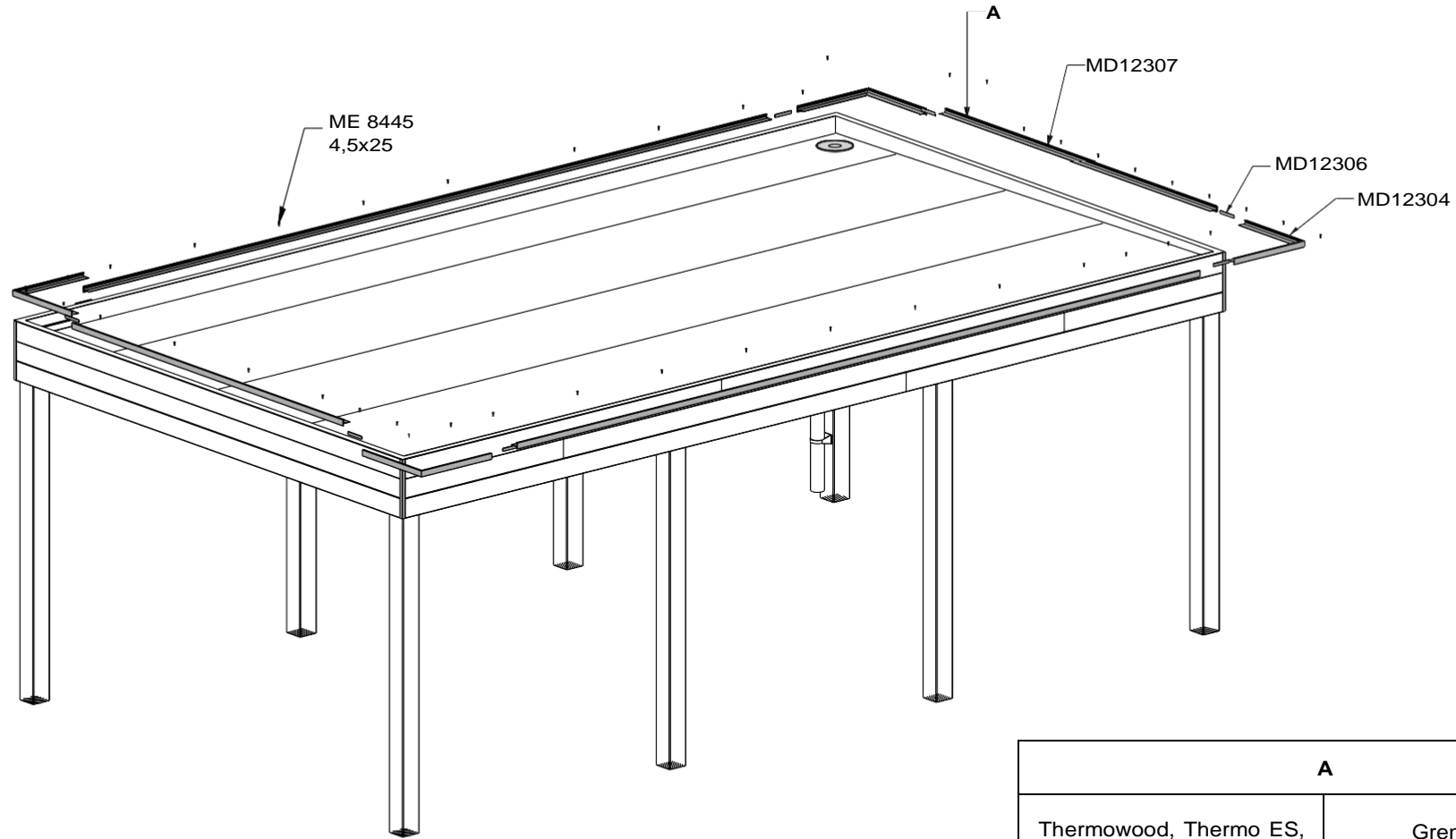

	MD12307 3000	MD12306	MD12304	ME8445 4,5x25
KA.12	6	12	4	38
KA.13	7	14	4	43
KA.14	9	18	4	49
KA.15	10	20	4	58



COLLSTROP

Wood for a better garden

BERGING/ABRI

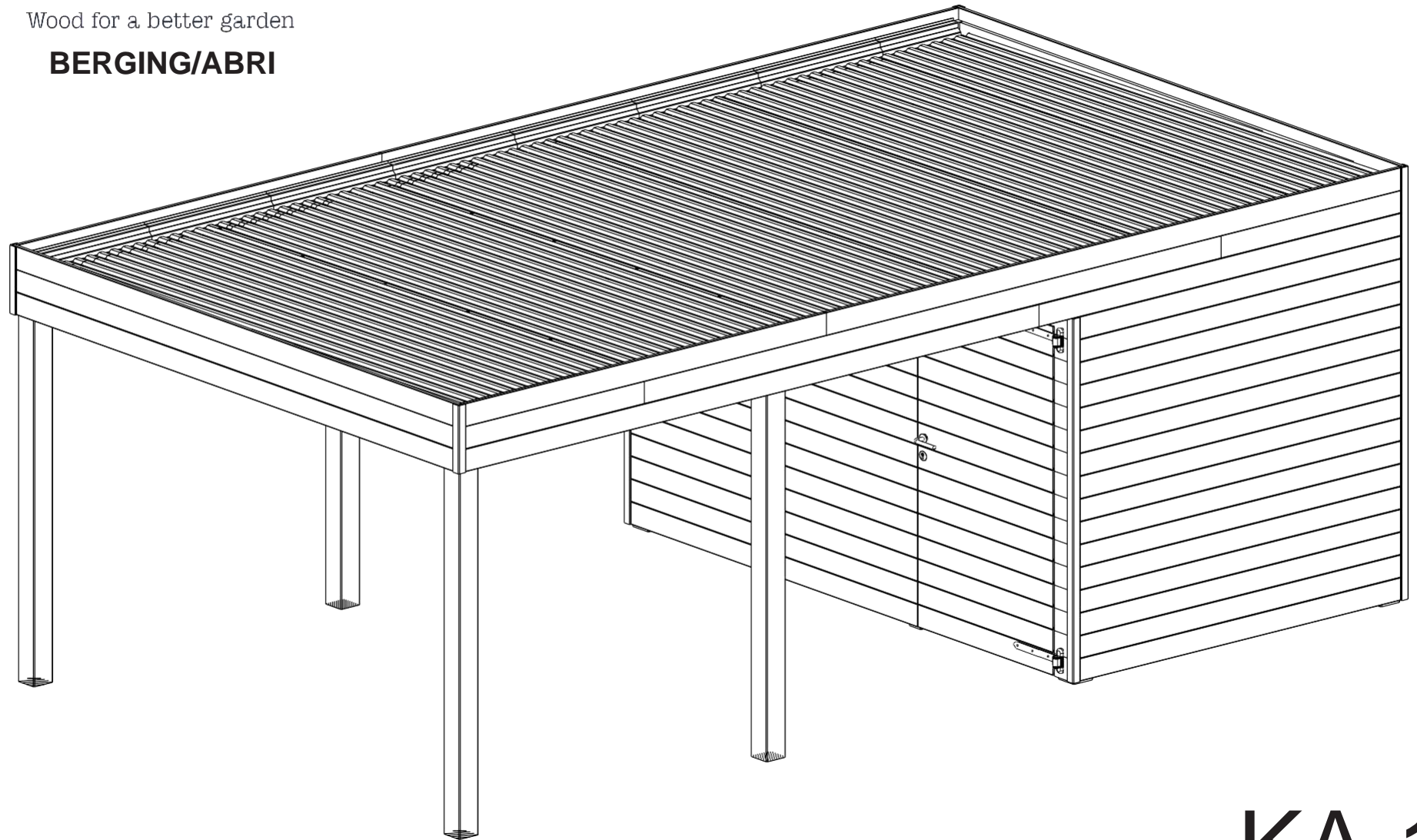

KA.1

FUNDERING
FONDATION

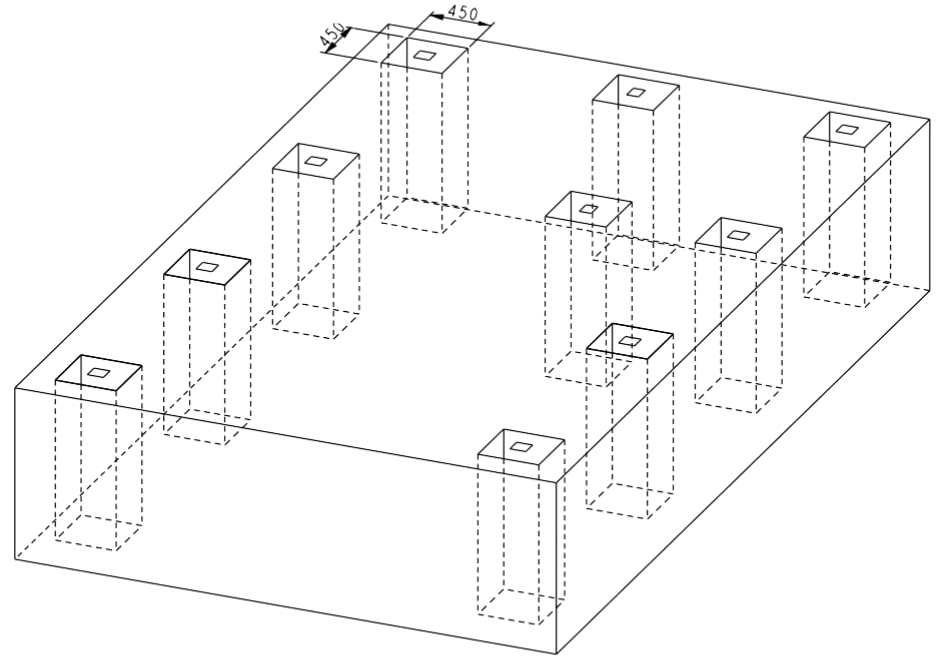
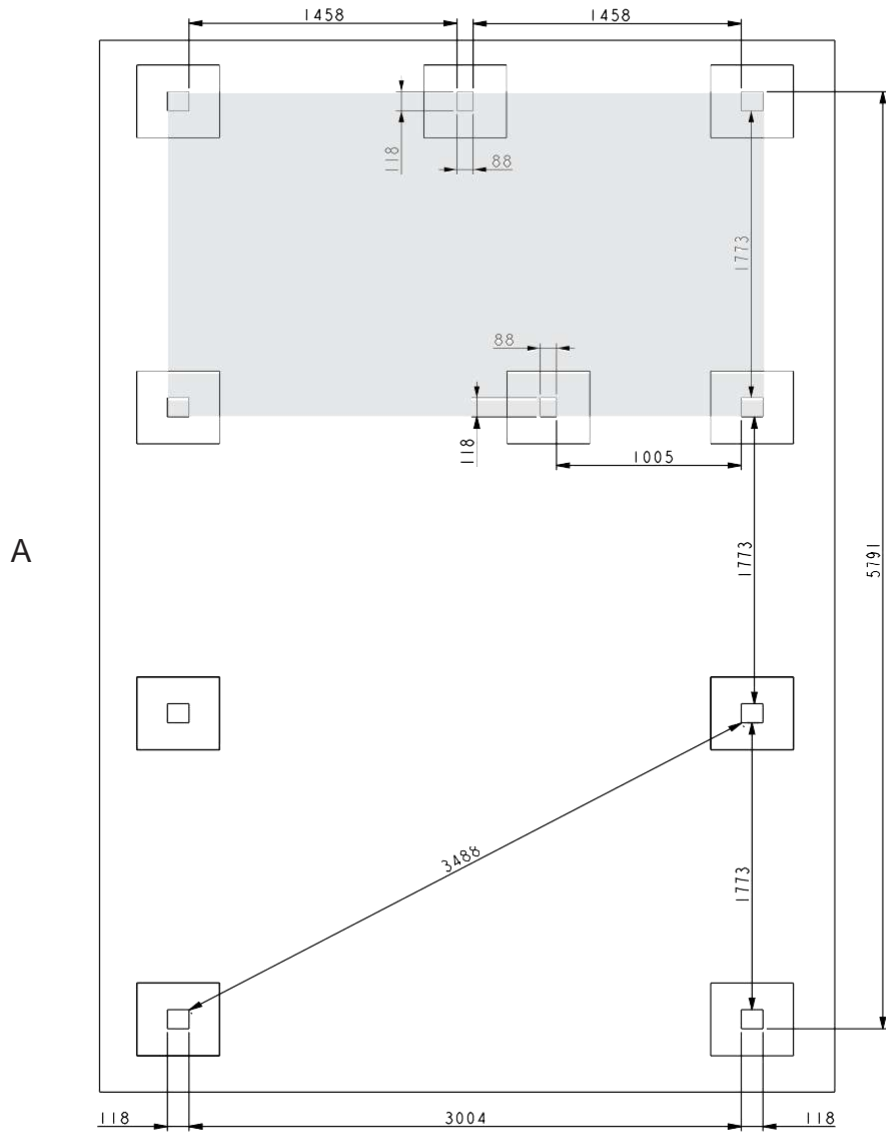

A	
KA.12	3X2
KA.13	4X2
KA.14	6X2
KA.15	8X2

FUNDERING
FONDATION

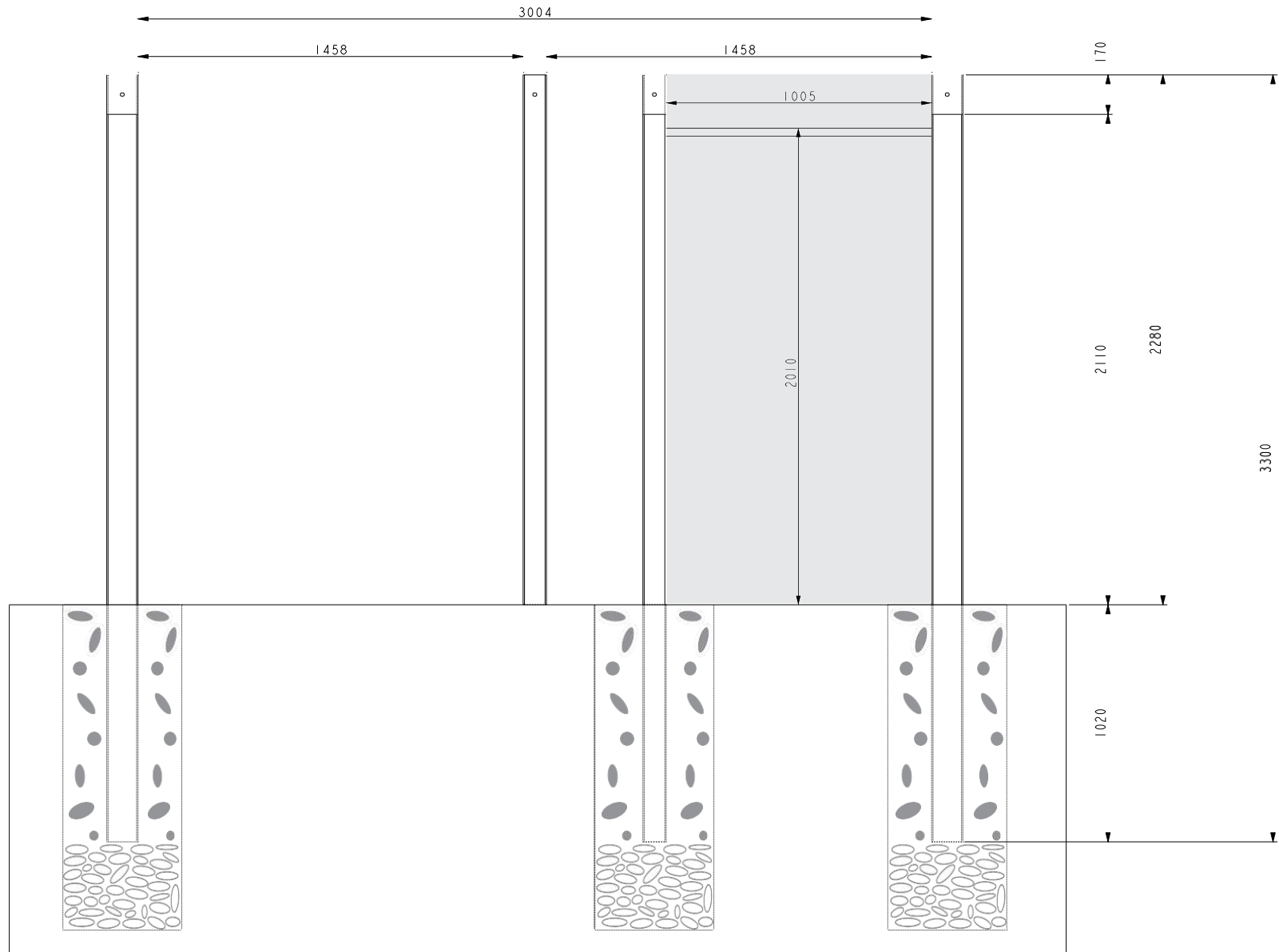

CONSTRUCTIE met berging
CONSTRUCTION avec abri

25

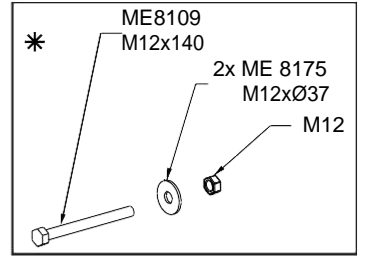

118x118

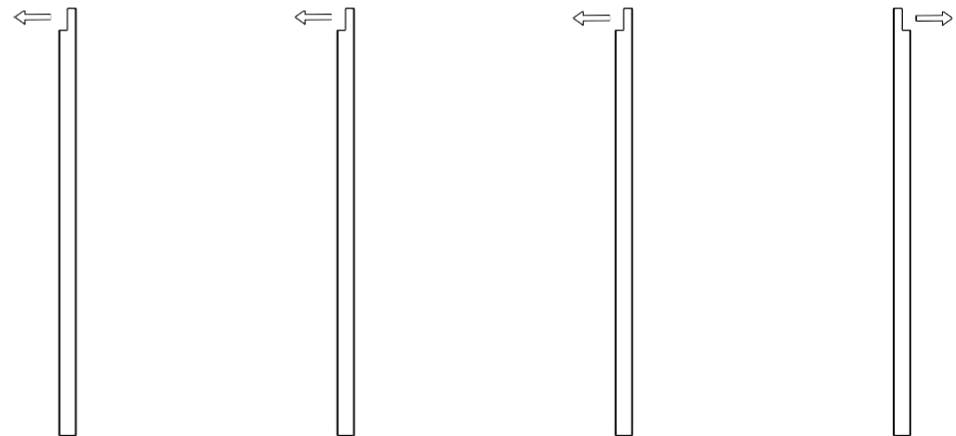
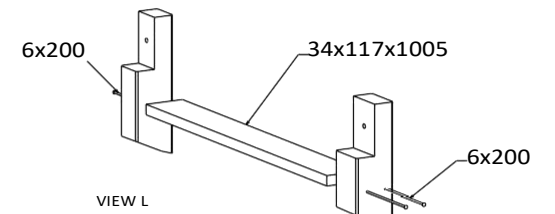
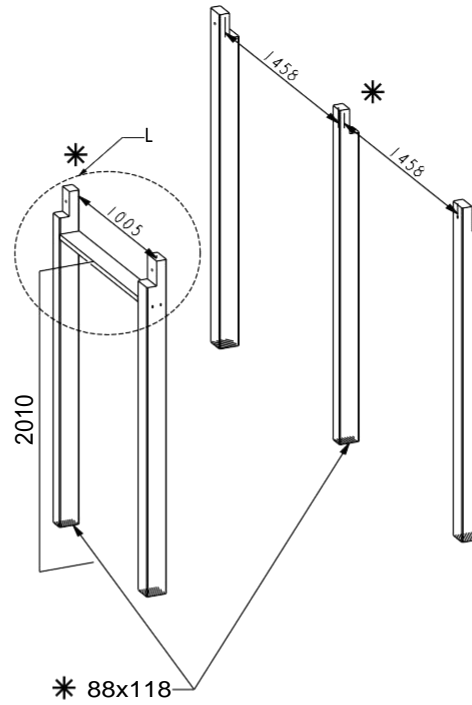
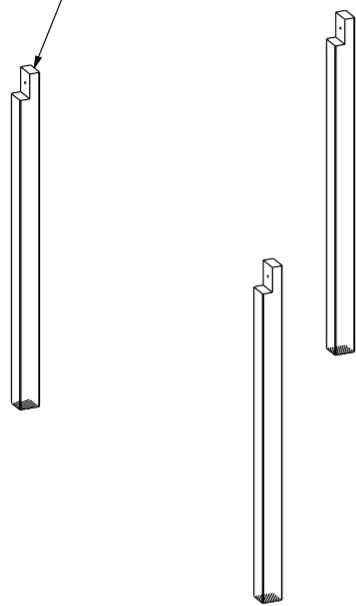

	118x118	34x117X1005	6x220	*			
				88x118	M8109 M12x140	M8175 M12xØ37	M12
KA.12	6	1	4	2	2	4	2
KA.13	8	1	4	2	2	4	2
KA.14	10	1	4	2	2	4	2
KA.15	12	1	4	2	2	4	2

Zie verder pag. 8

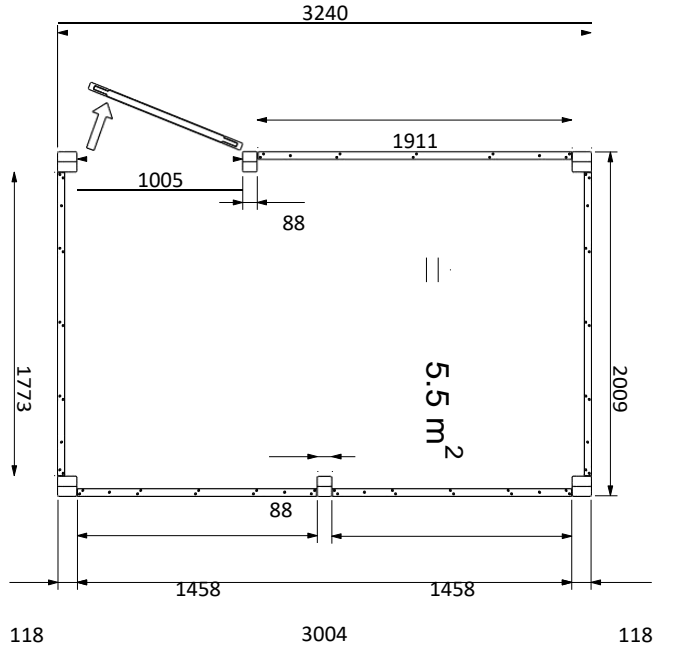
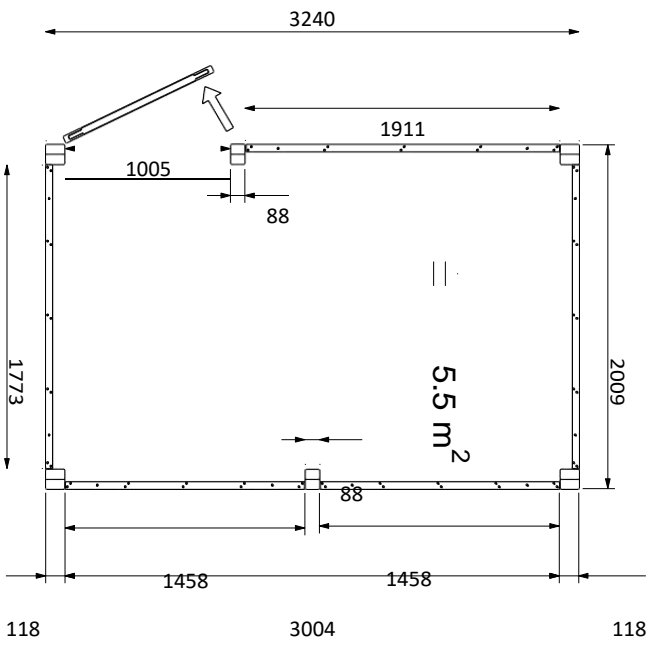

KA.15

KA.14

KA.13

KA.12

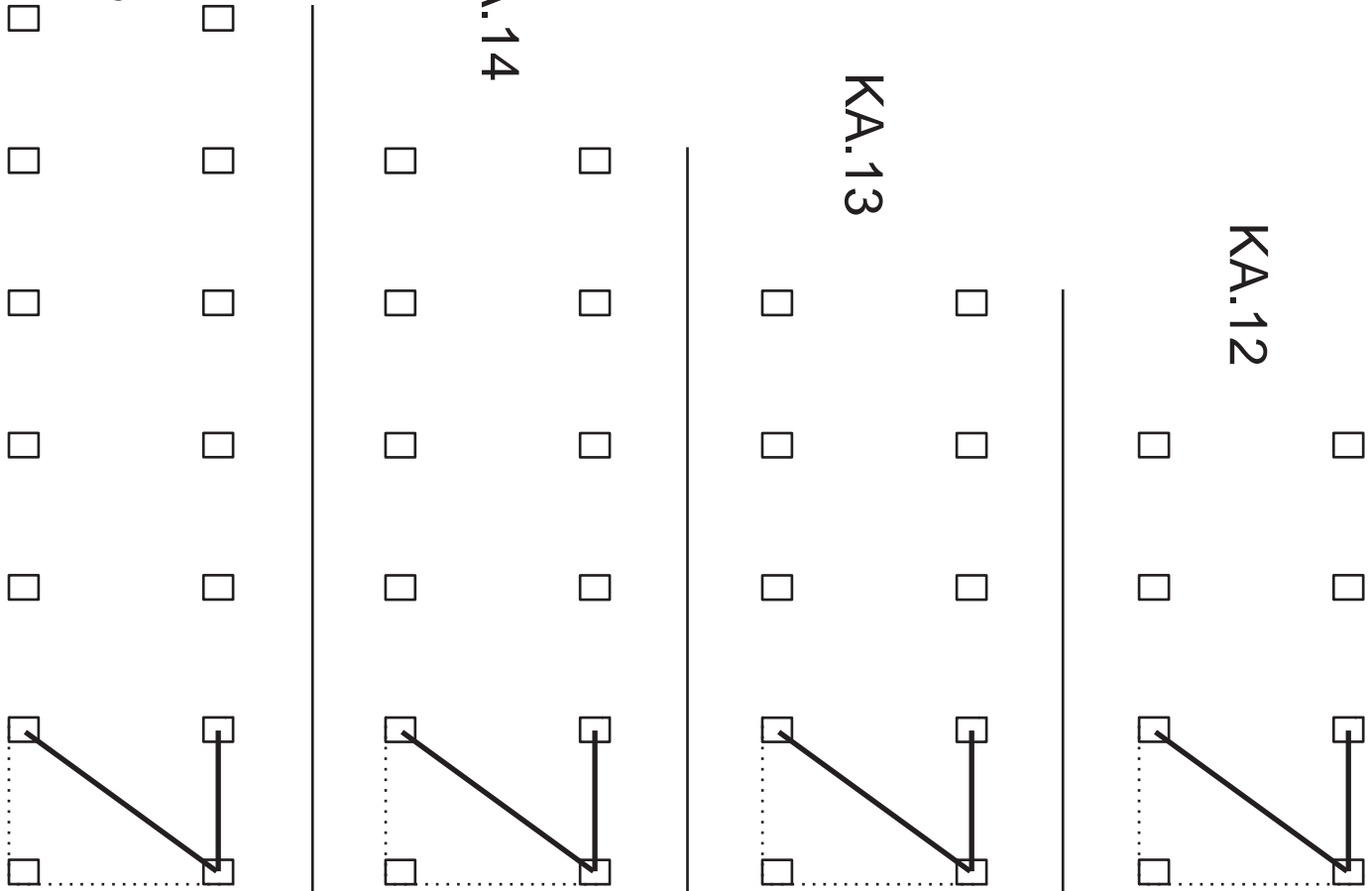

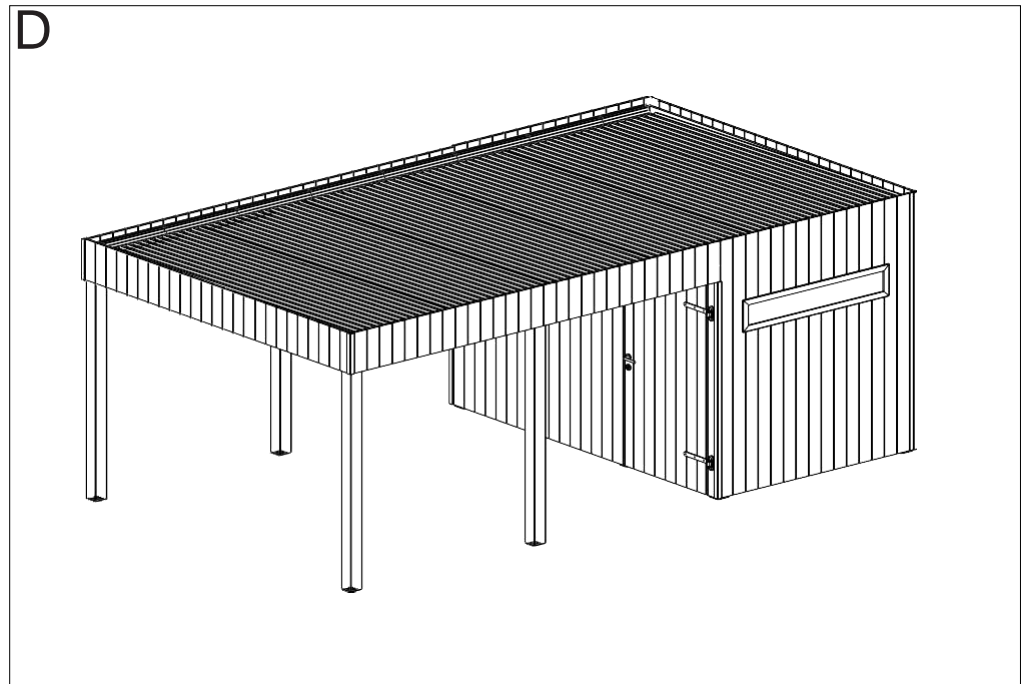
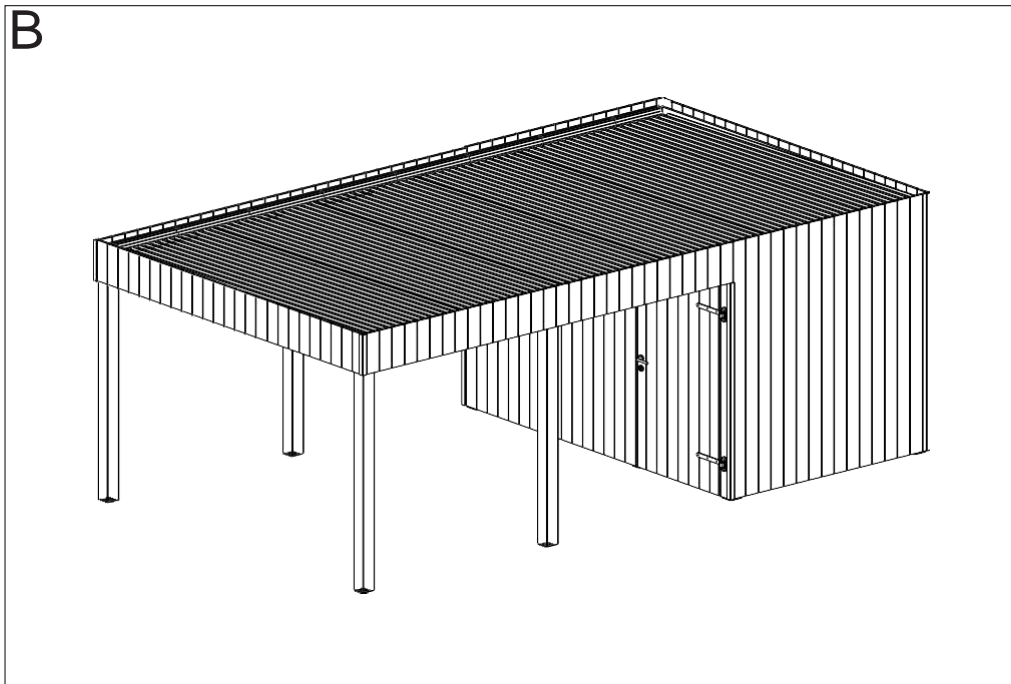
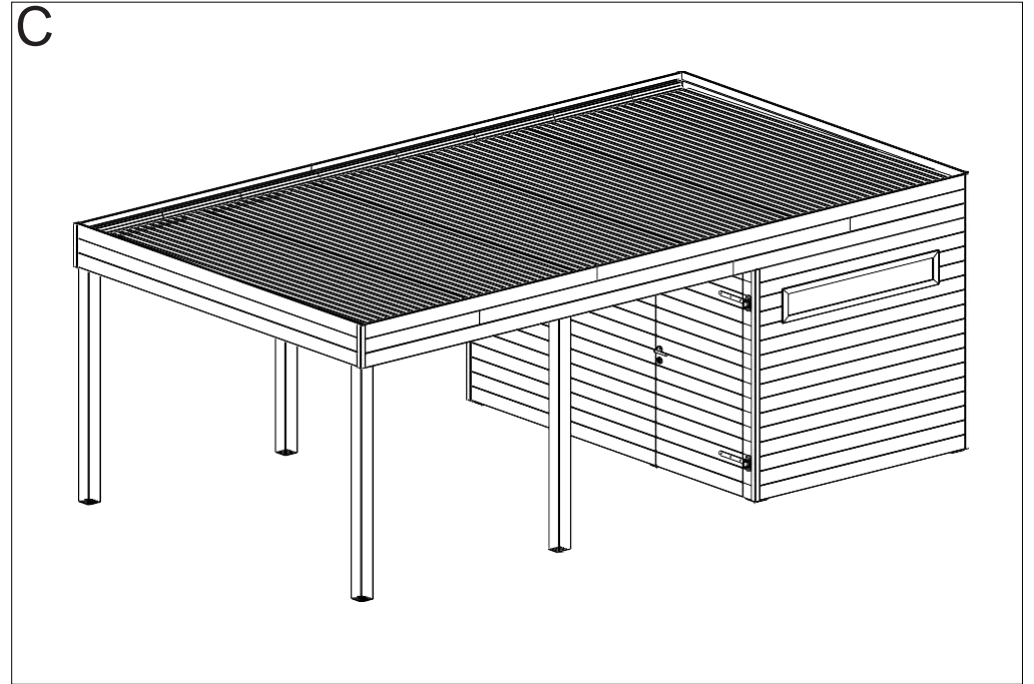
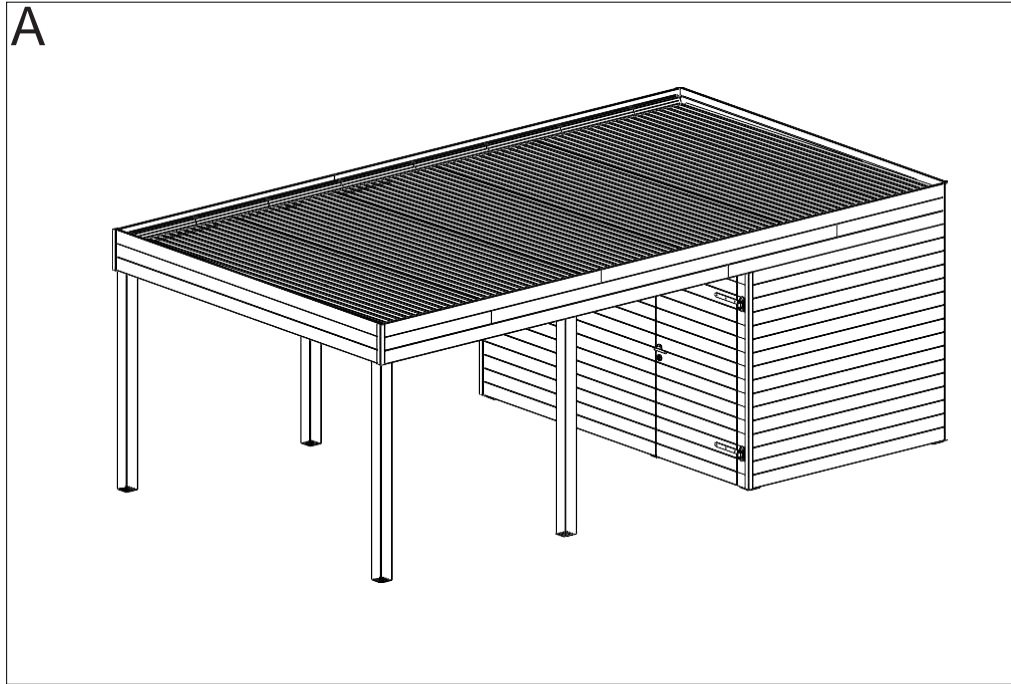

A

☆
25

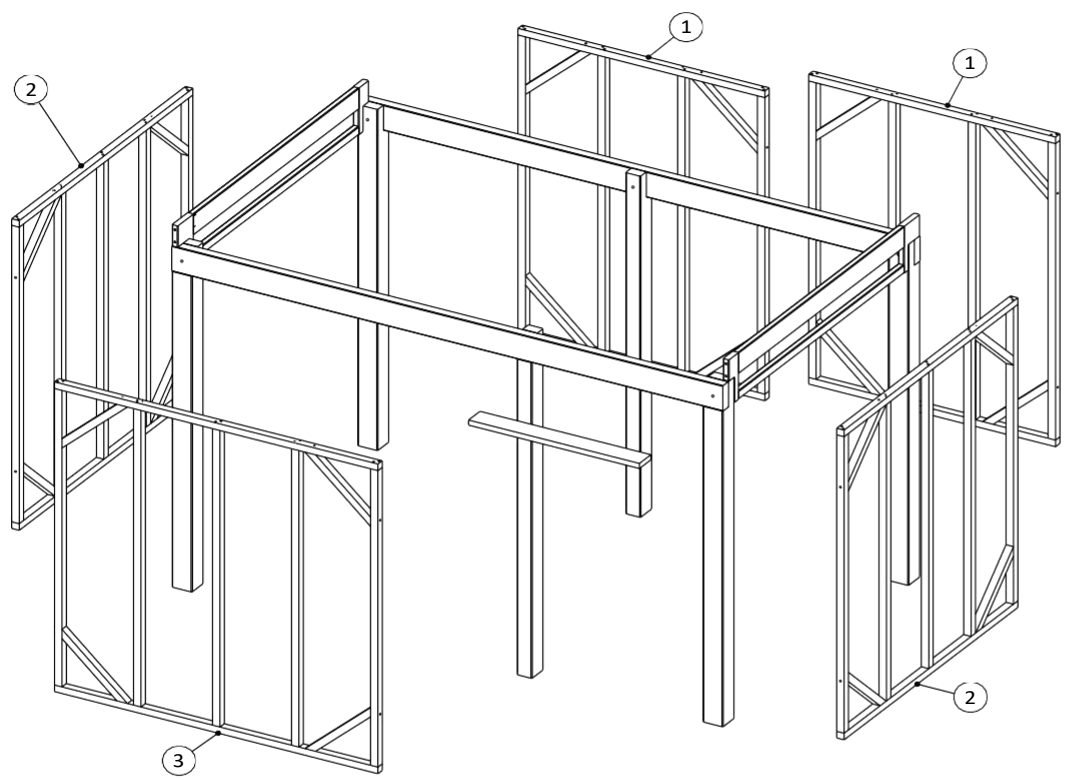

1xEW = 6x ME8420
5x80 A2

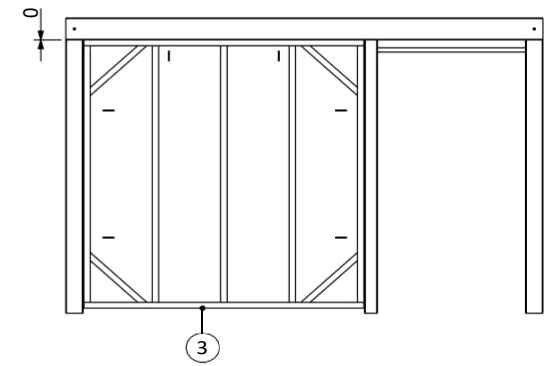
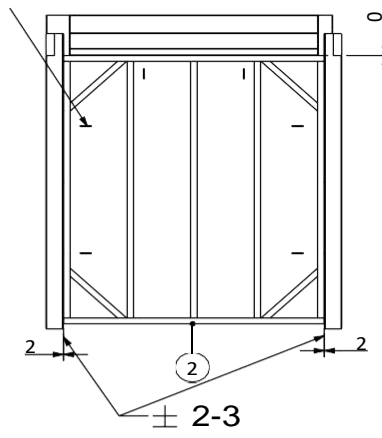

1x EW= 5x ME8420
5x80 A2

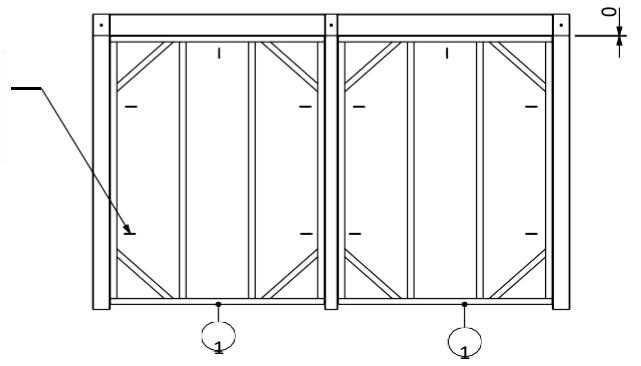

ME8420
5x80 A2

1	EW	2070x1452	x2	10
2	EW	2070x1769	x2	12
3	EW	2070x1902	x1	6

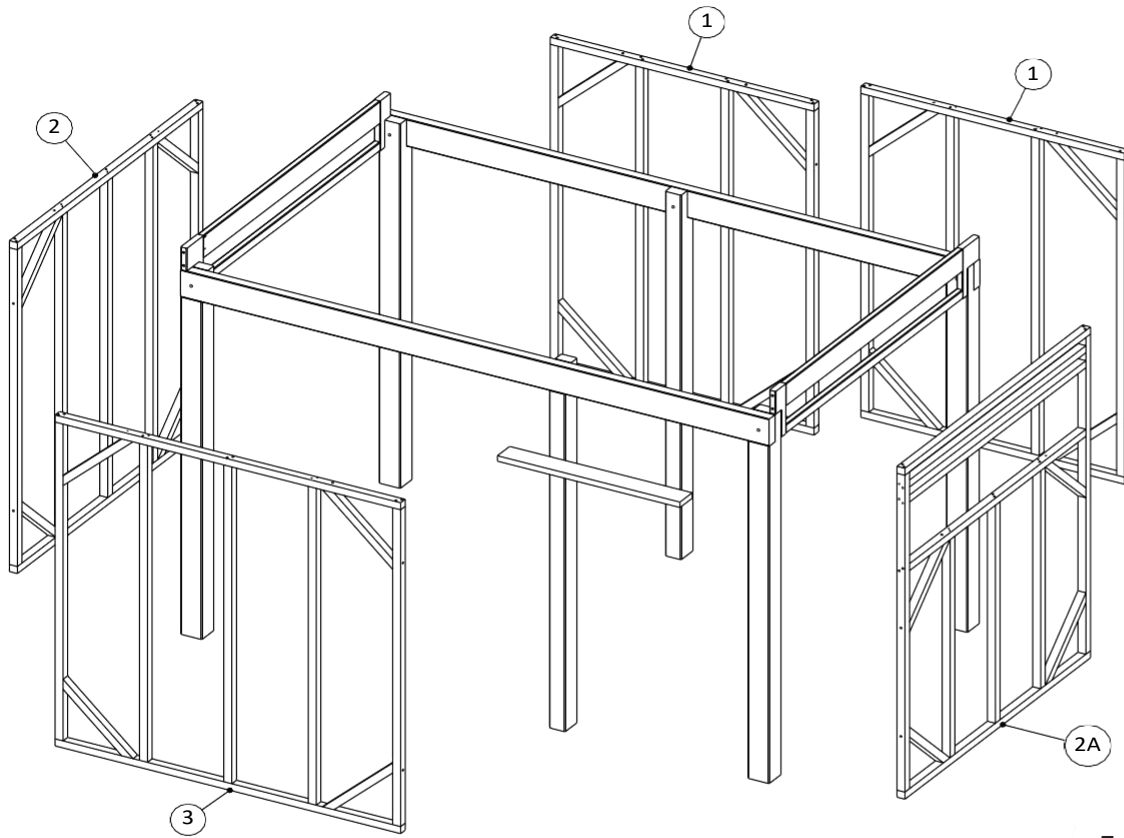

1xEW = 6x ME8420
5x80 A2

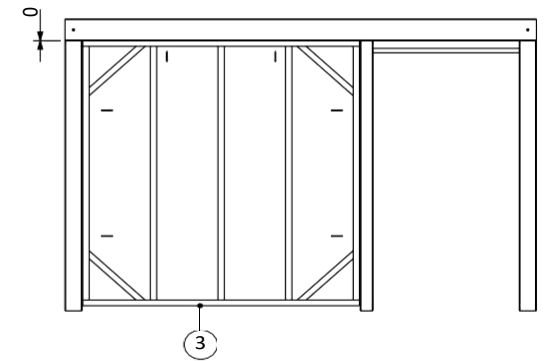
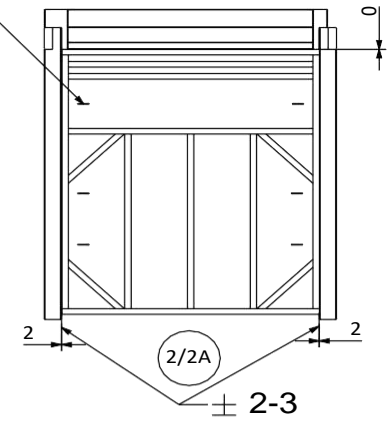

1x EW= 5x ME8420
5x80 A2

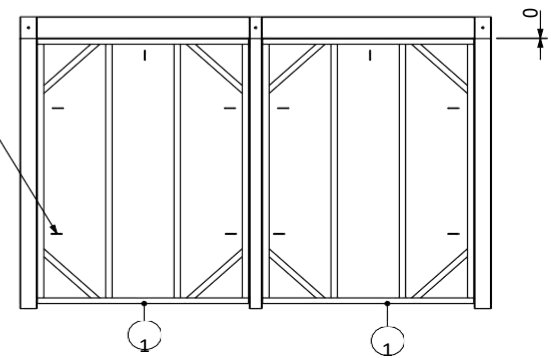

				ME8420 5x80 A2
1	EW	2070x1452	x2	10
2	EW	2070x1769	x1	6
2A	EW raam	2070x1769	x1	6
3	EW	2070x1902	x1	6

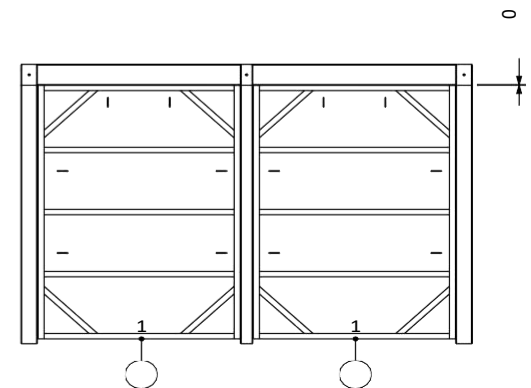
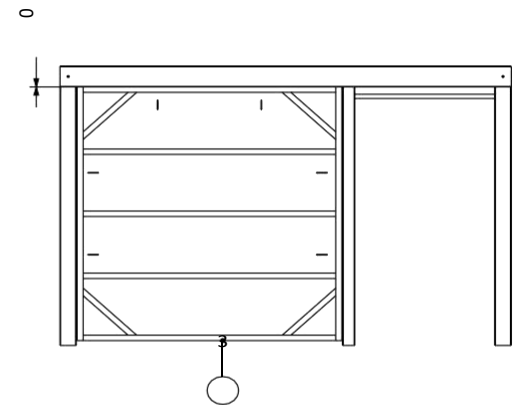
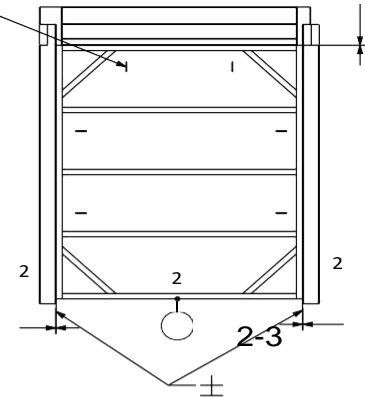
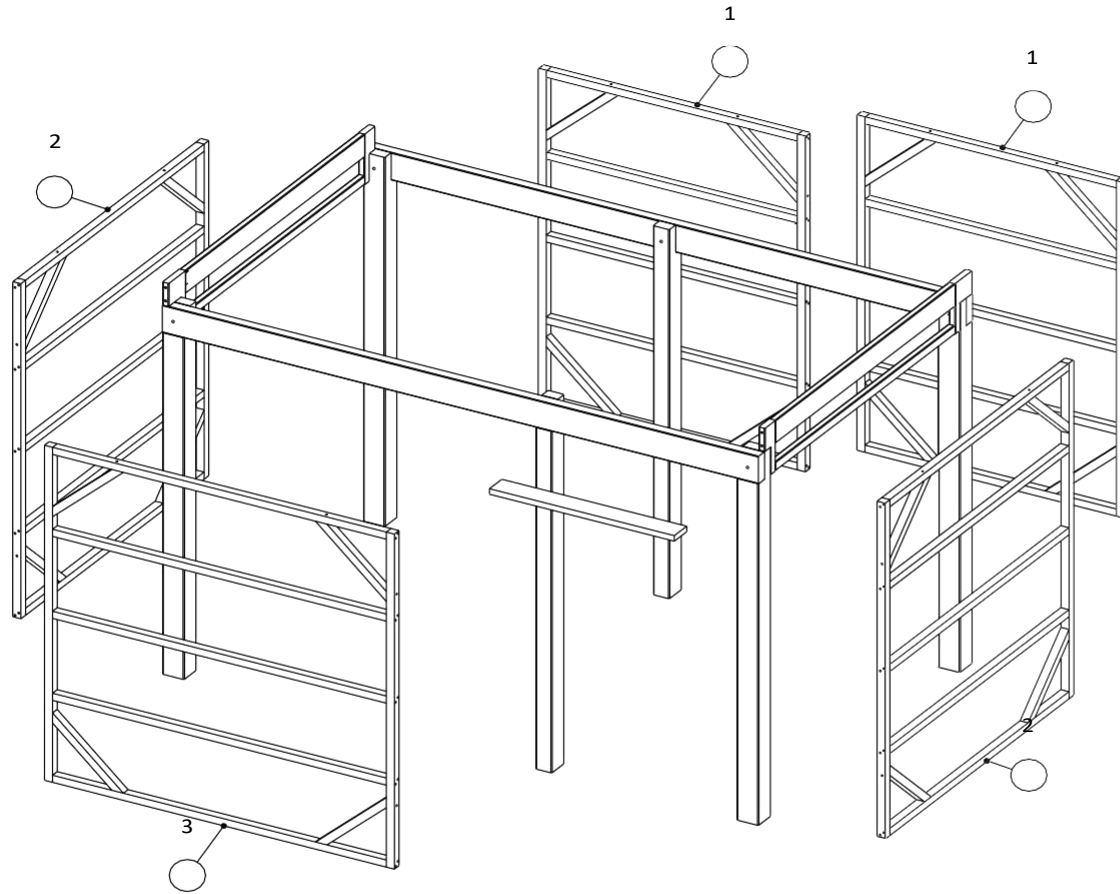

ME8420
5x80 A2

1	EW	2070x1452	x2	12
2	EW	2070x1769	x2	12
3	EW	2070x1902	x1	6

Draaideur
Porte tournante

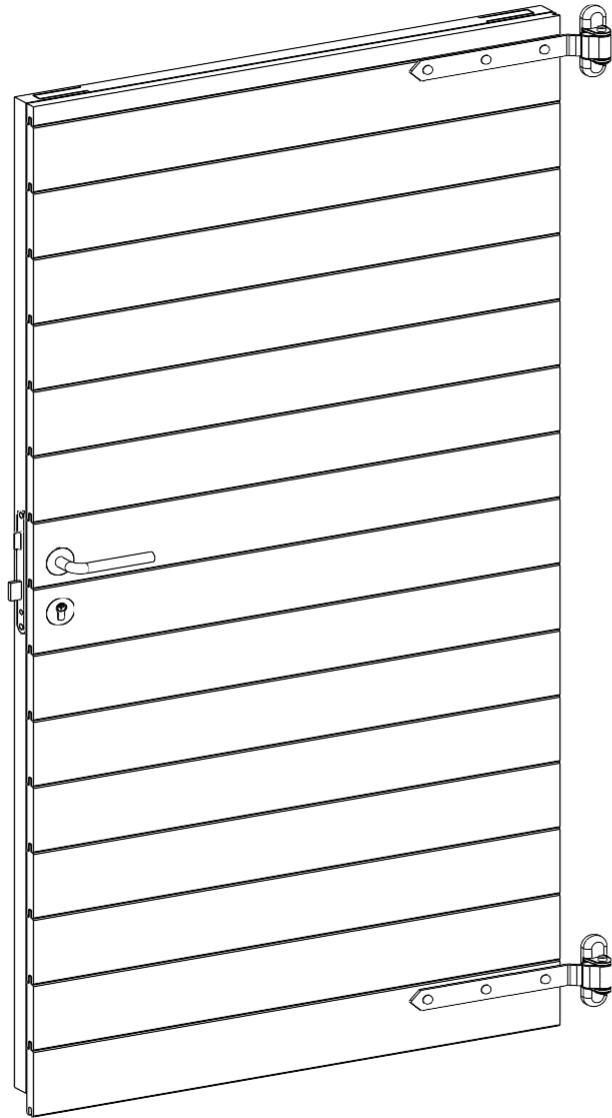

Schuifdeur
Porte coulissante

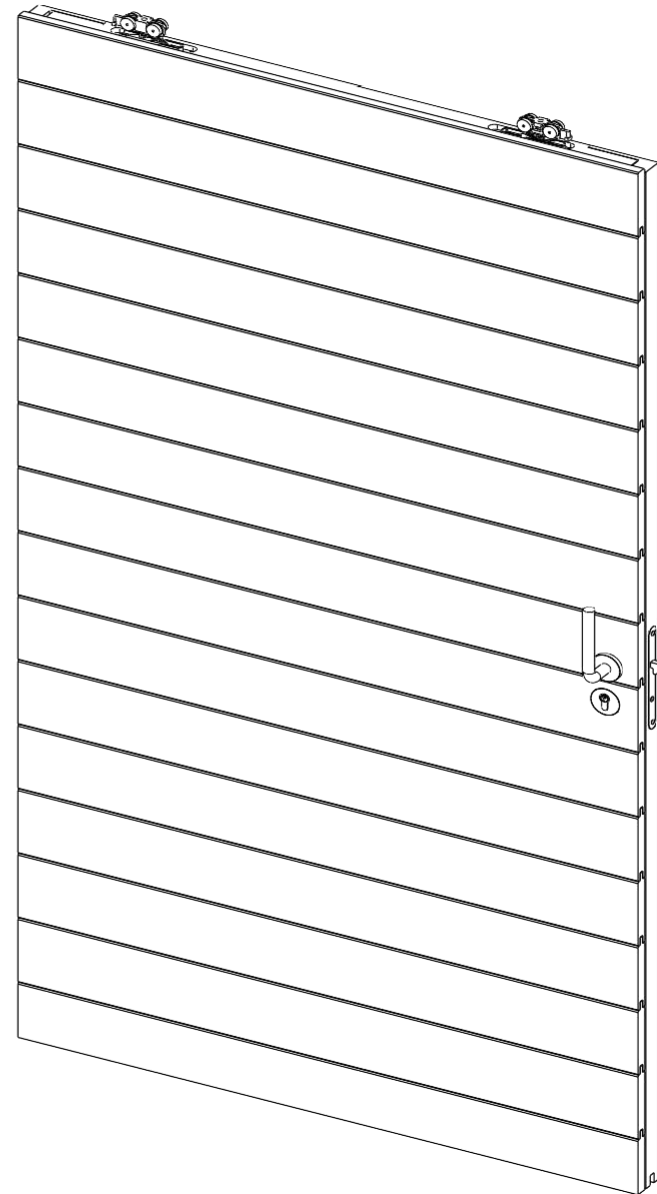

Stukkenlijst draaideur
 Liste des pieces porte tournante

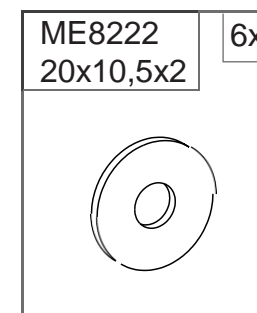
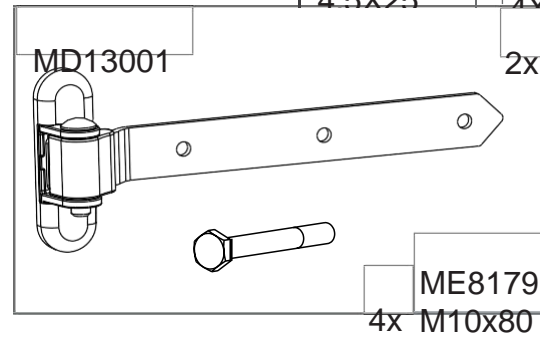
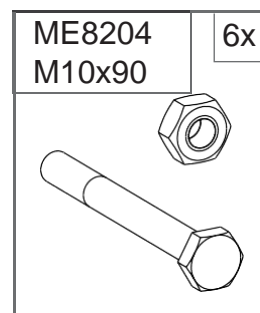
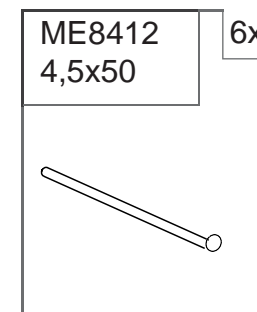
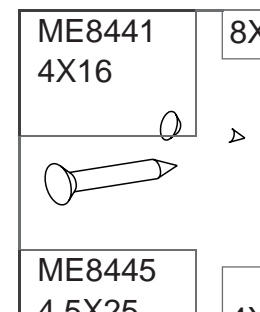
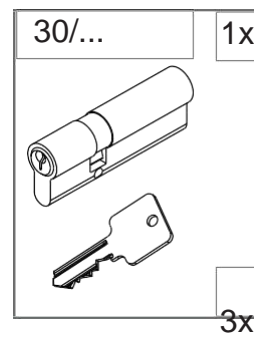
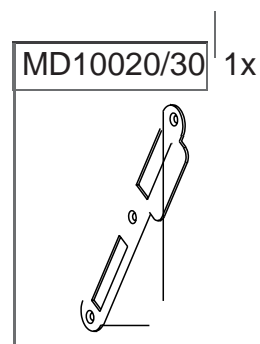
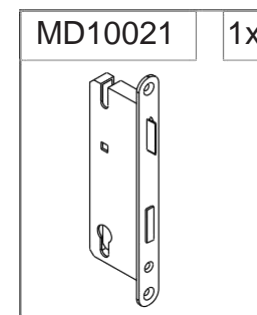
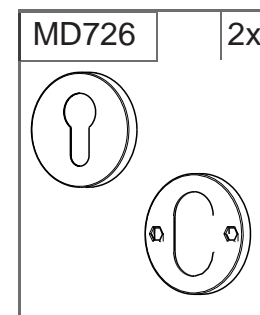
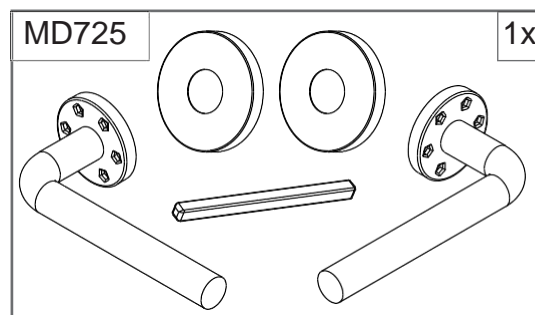
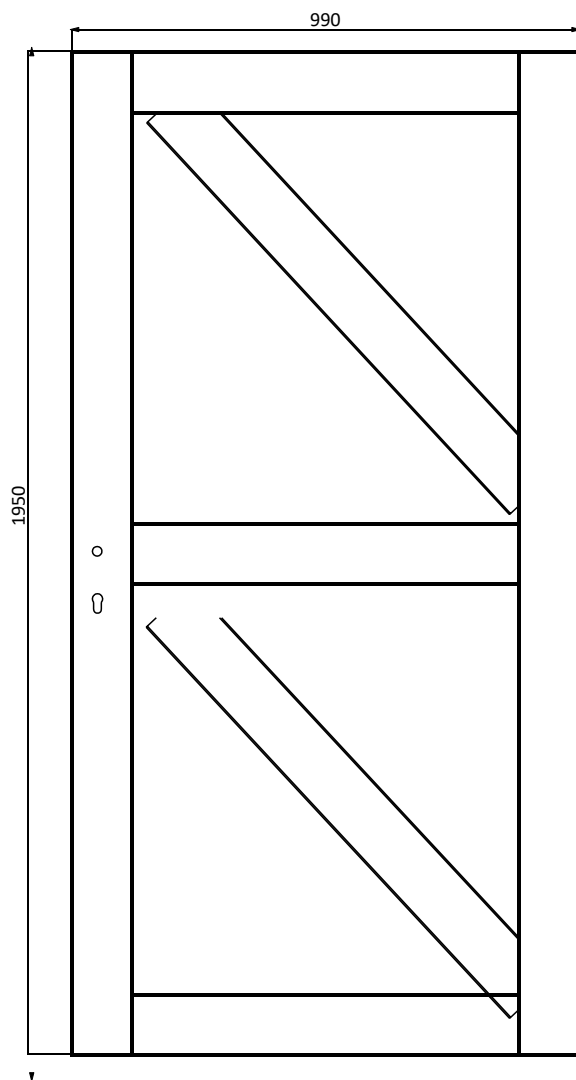

Assemblage draaideur
Assemblée porte tournante

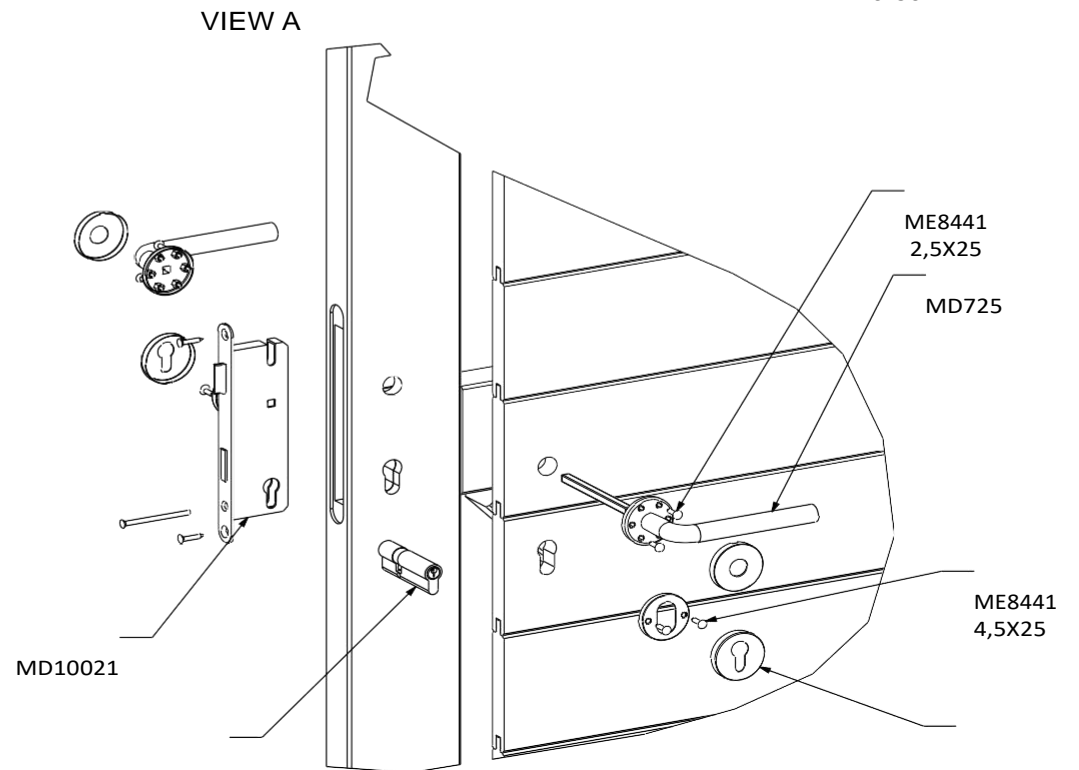
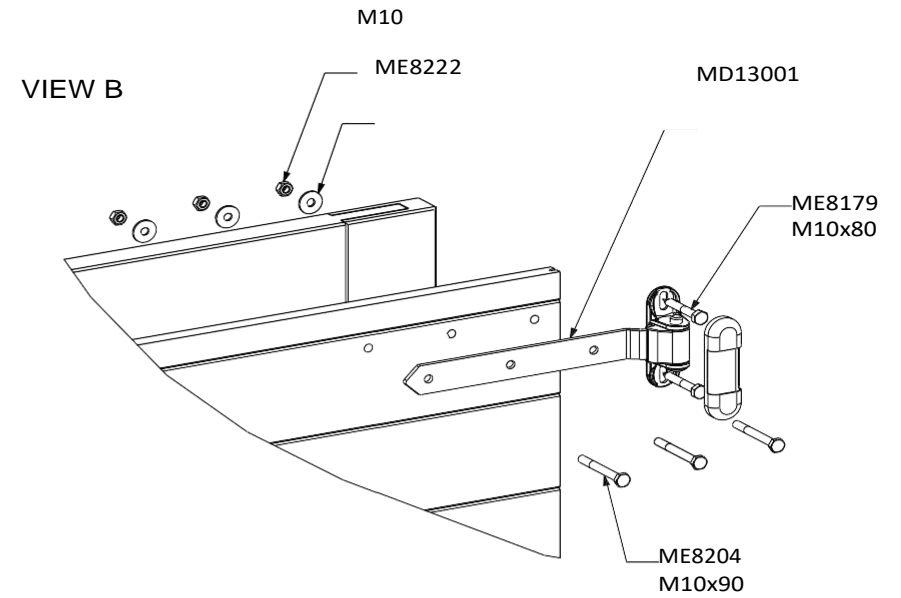
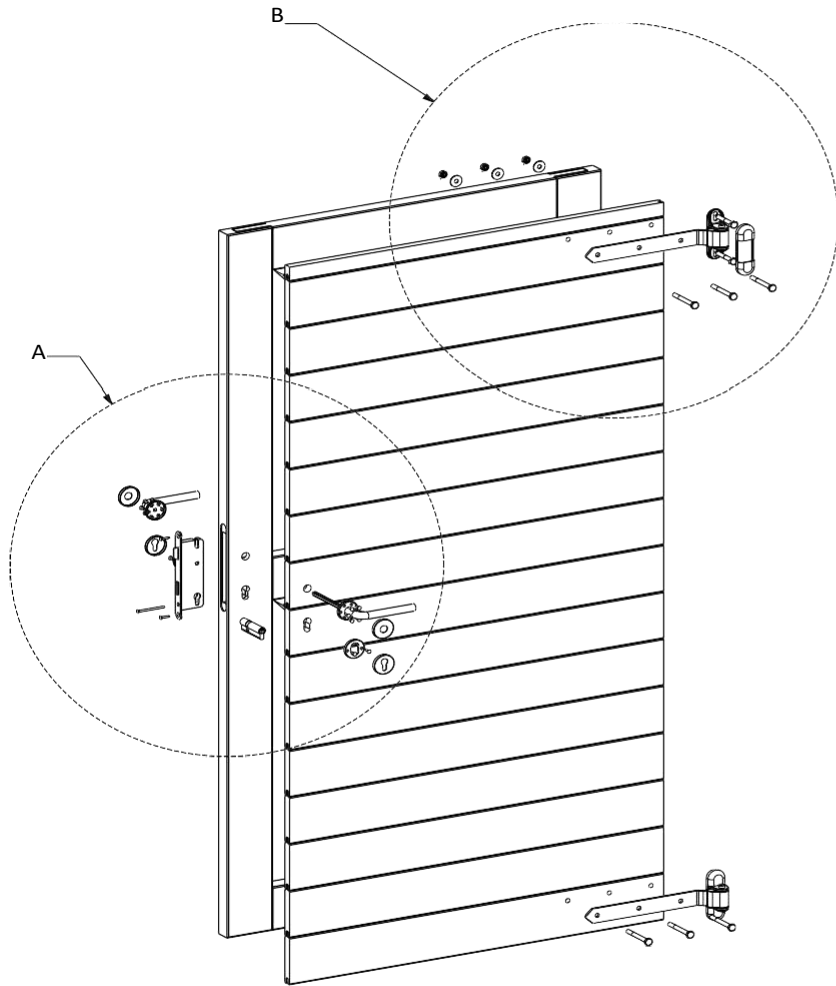

MD726

Afwerking draaideur
Finition de la porte tournante

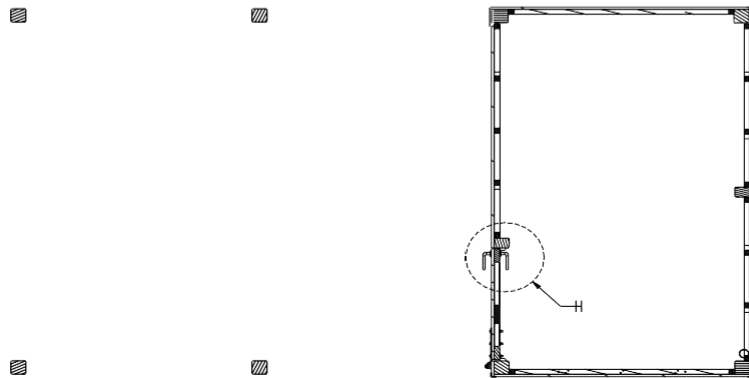
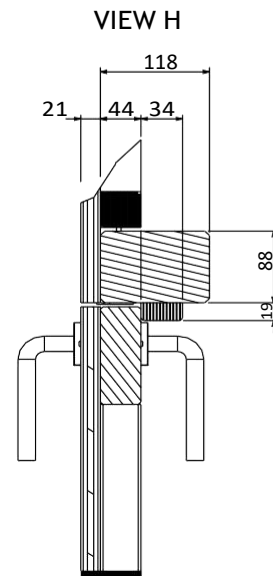
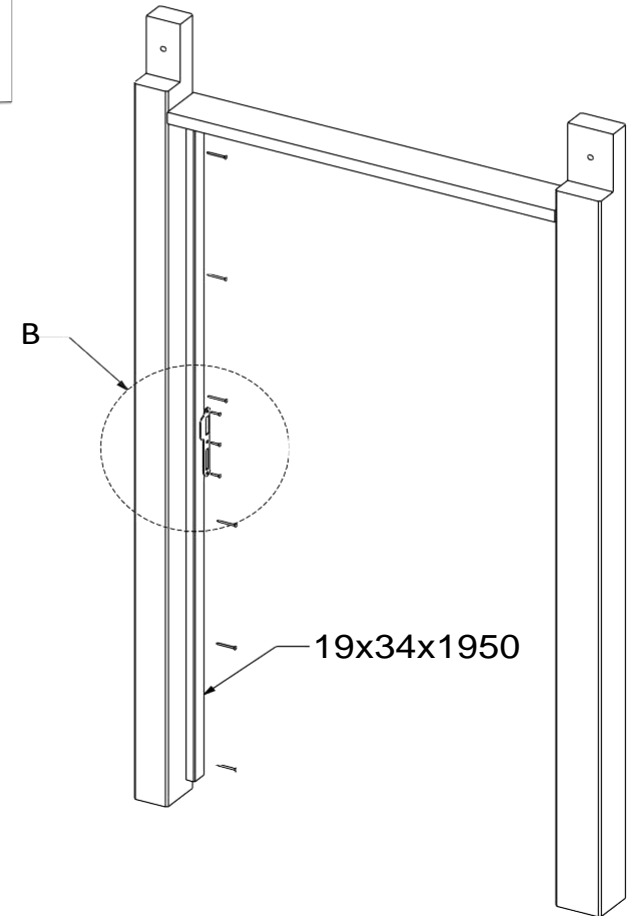
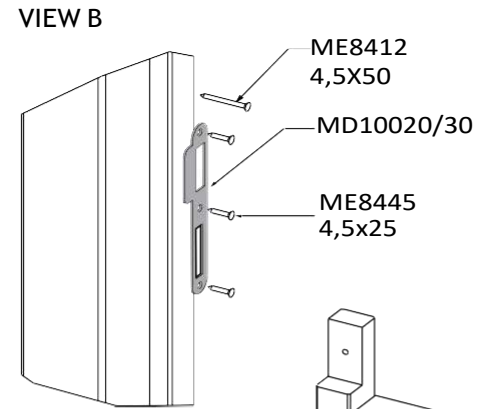
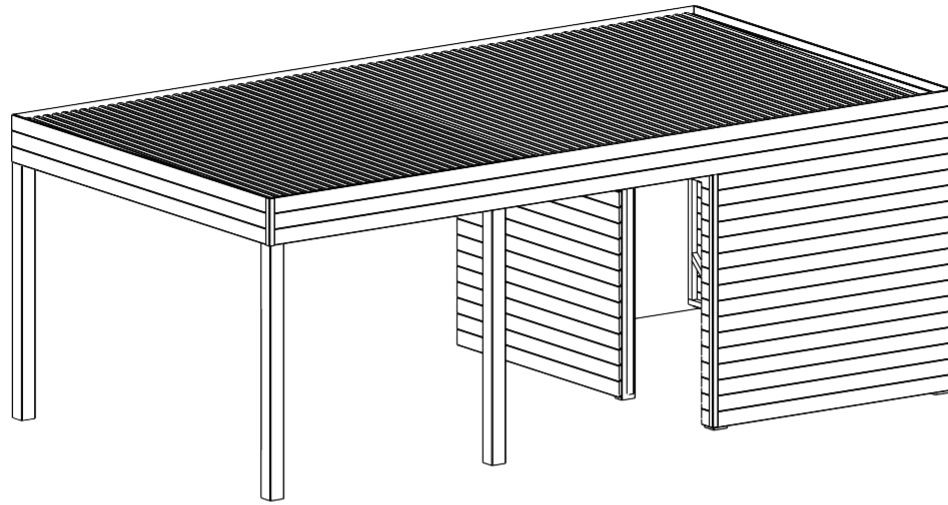

Stukkenlijst schuifdeur
 Liste des pieces porte coulissante

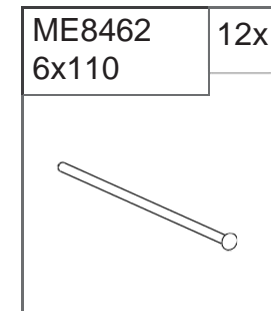
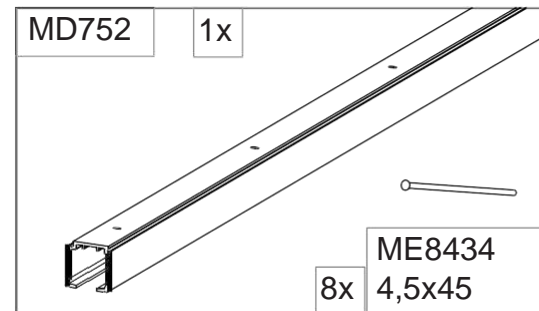
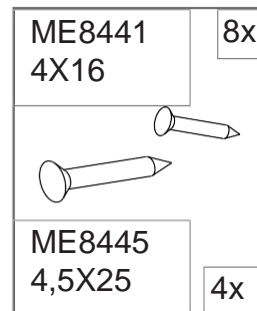
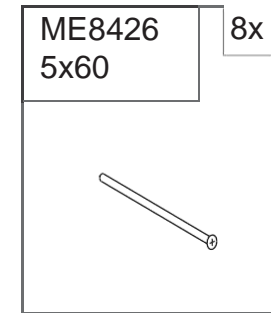
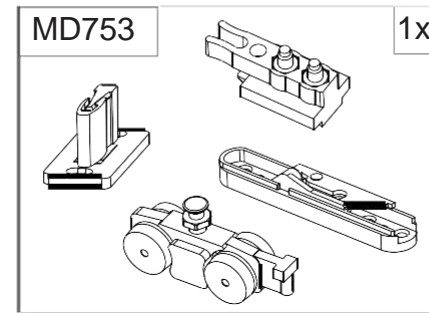
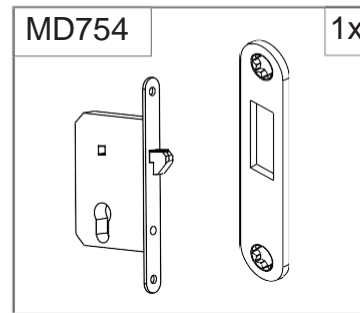
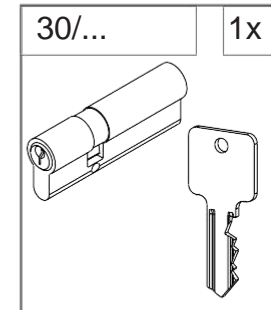
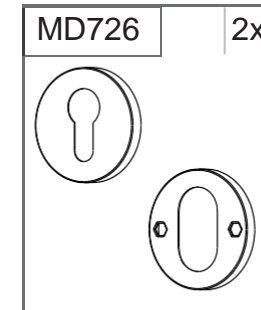
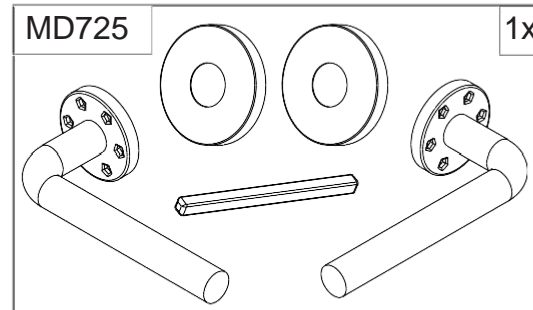
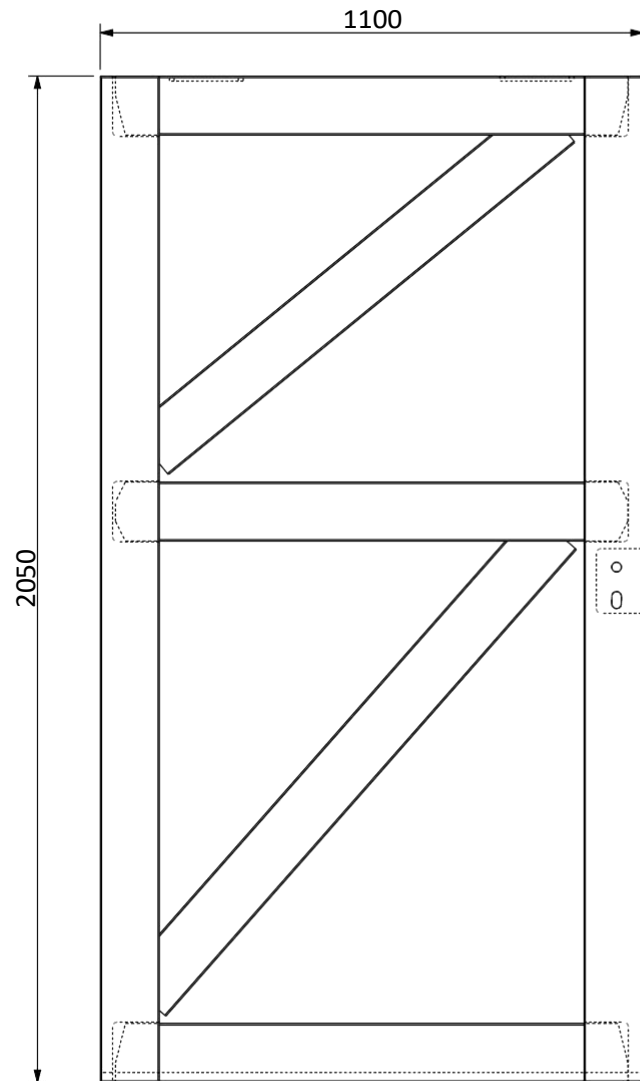

Assemblage schuifdeur
Assemblée porte coulissante

MD753:
Zie handleiding van de fabrikant.
Voir notice du fabricant.

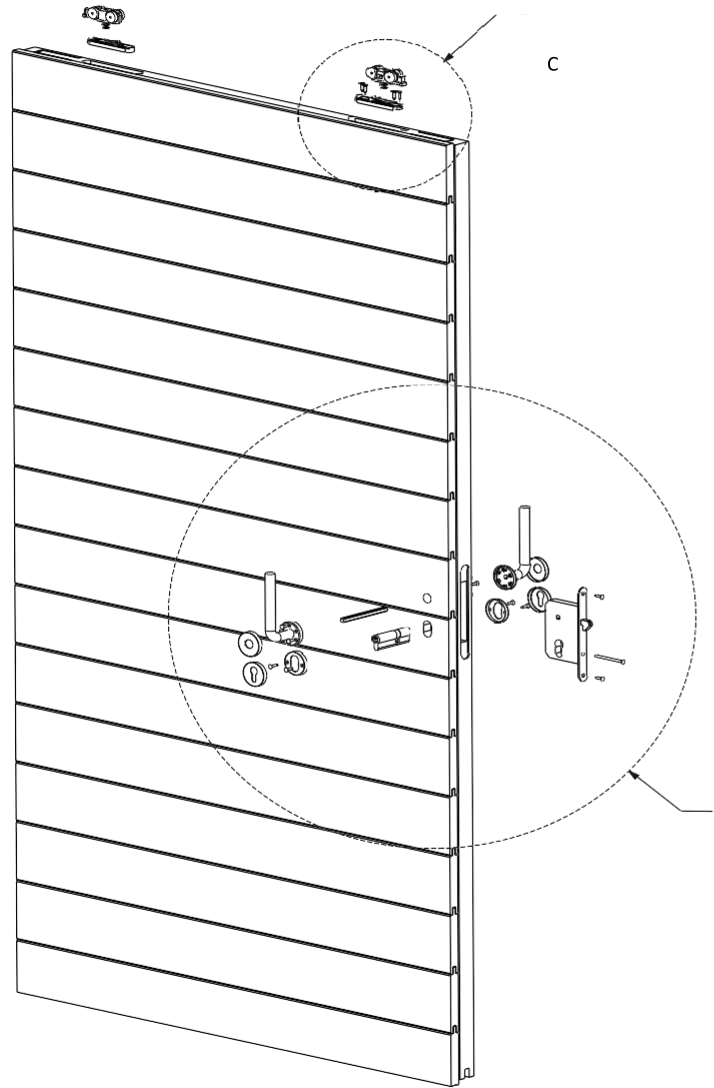

VIEW C

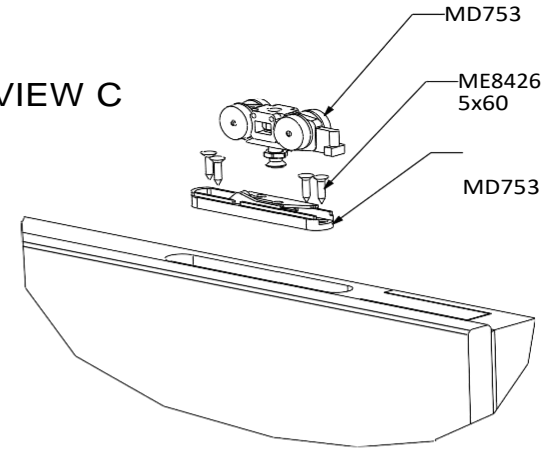

VIEW B

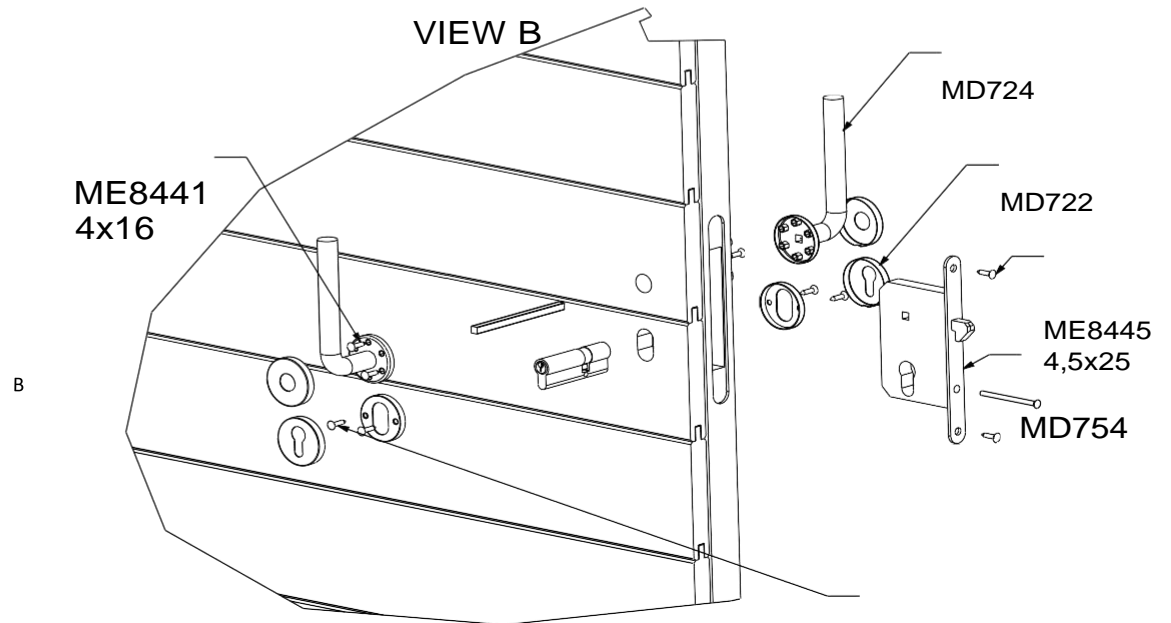

ME8441

4x16

Assemblage schuifdeur 1
 Assemblée porte coulissante 1

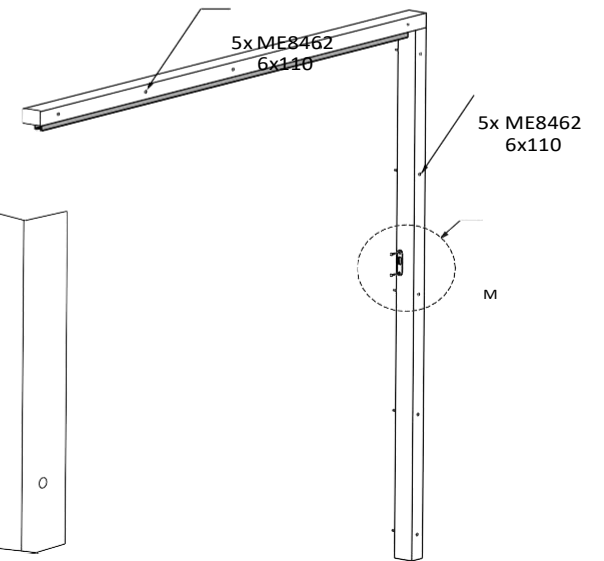
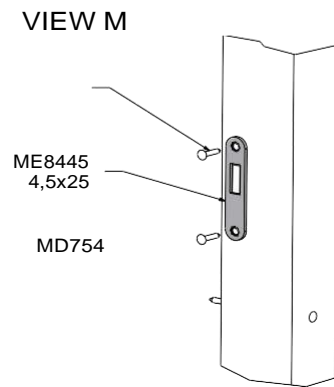
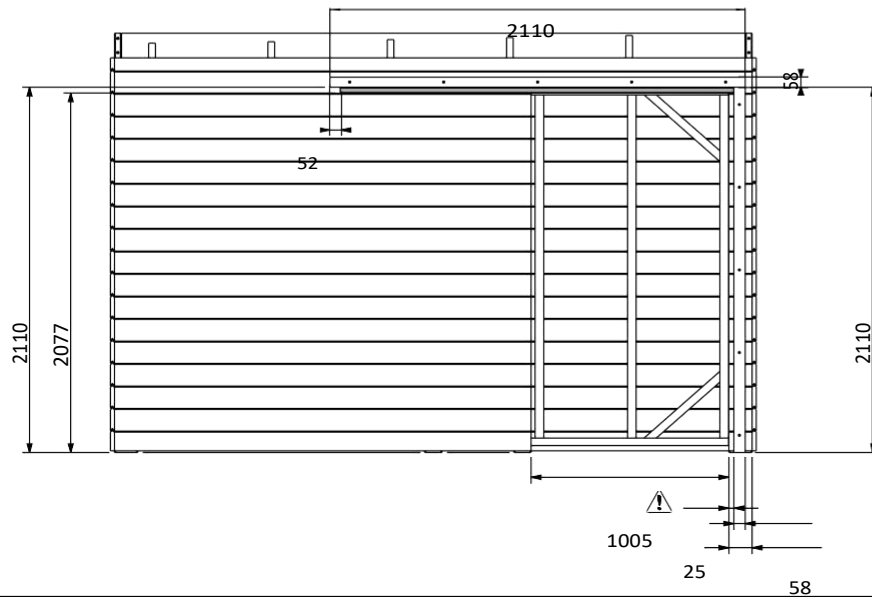
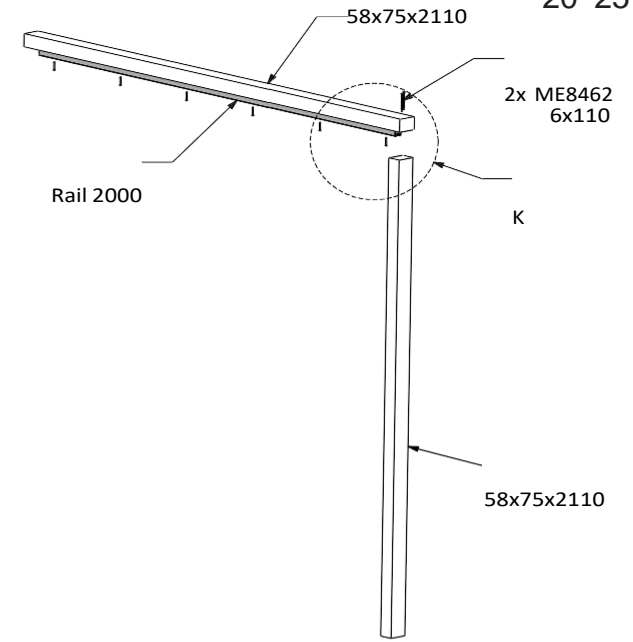
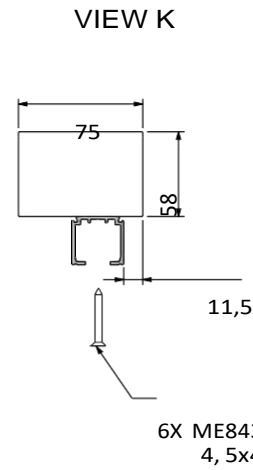
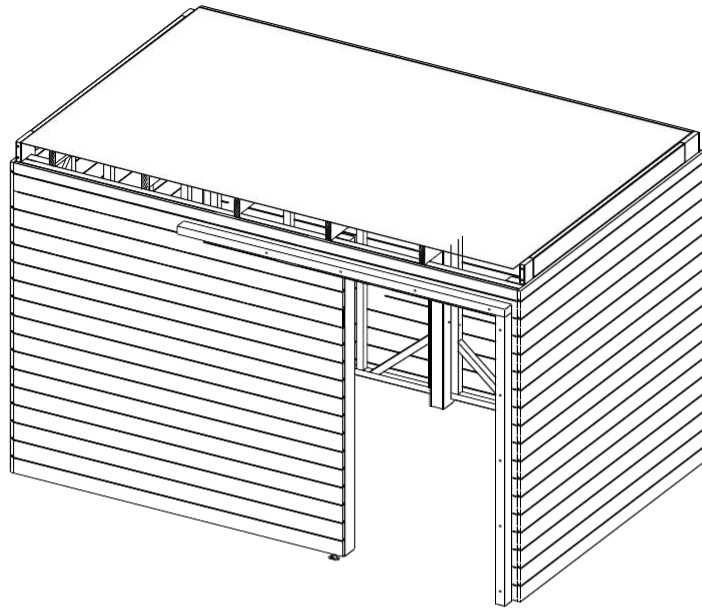

Assemblage schuifdeur 2
 Assemblée porte coulissante 2

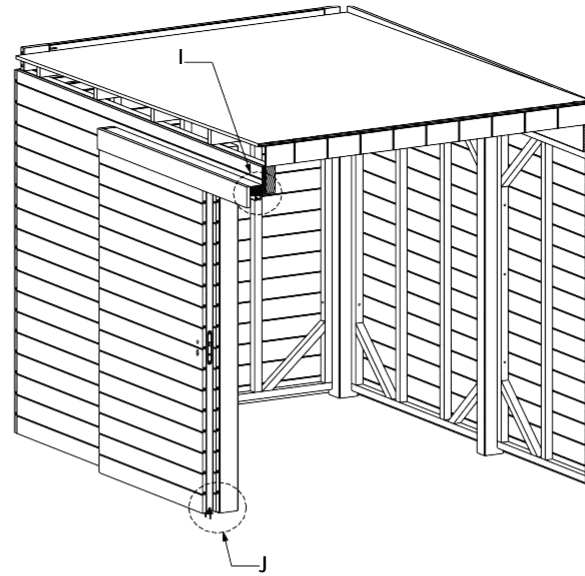
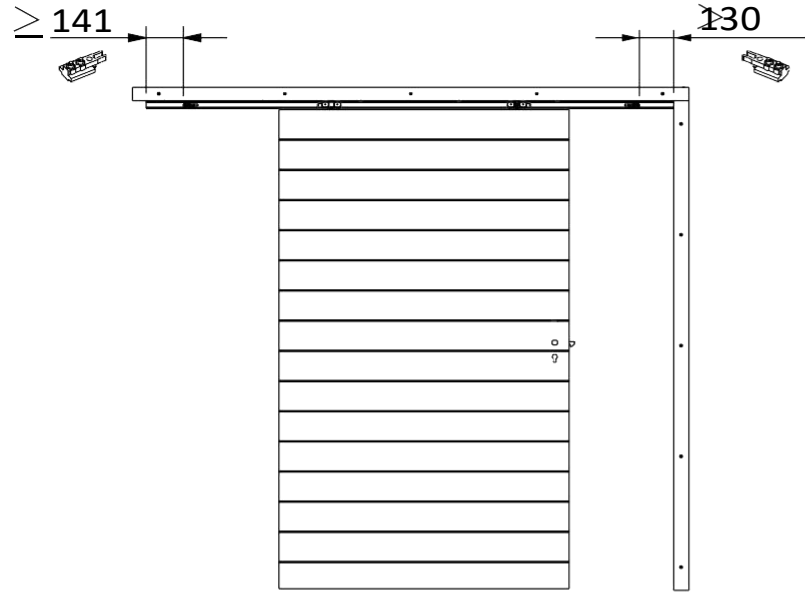

VIEW J

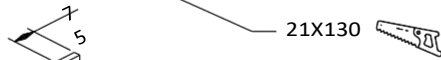
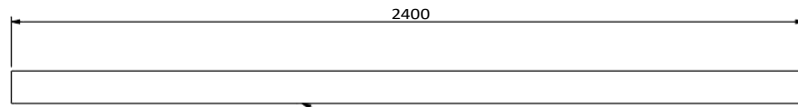
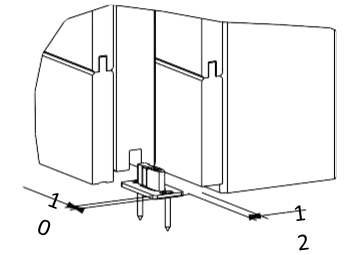

VIEW I

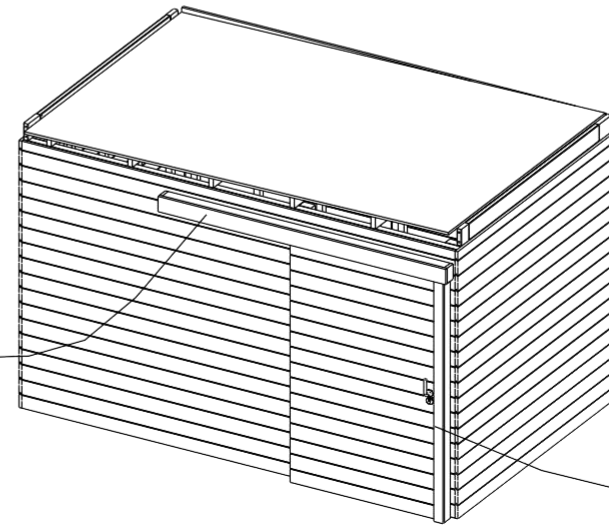
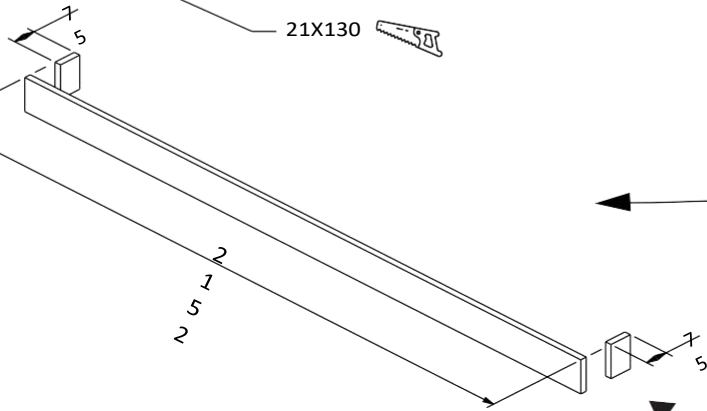
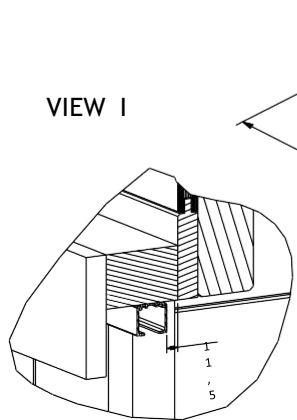

21×68



Meegelerd/ Fourni