

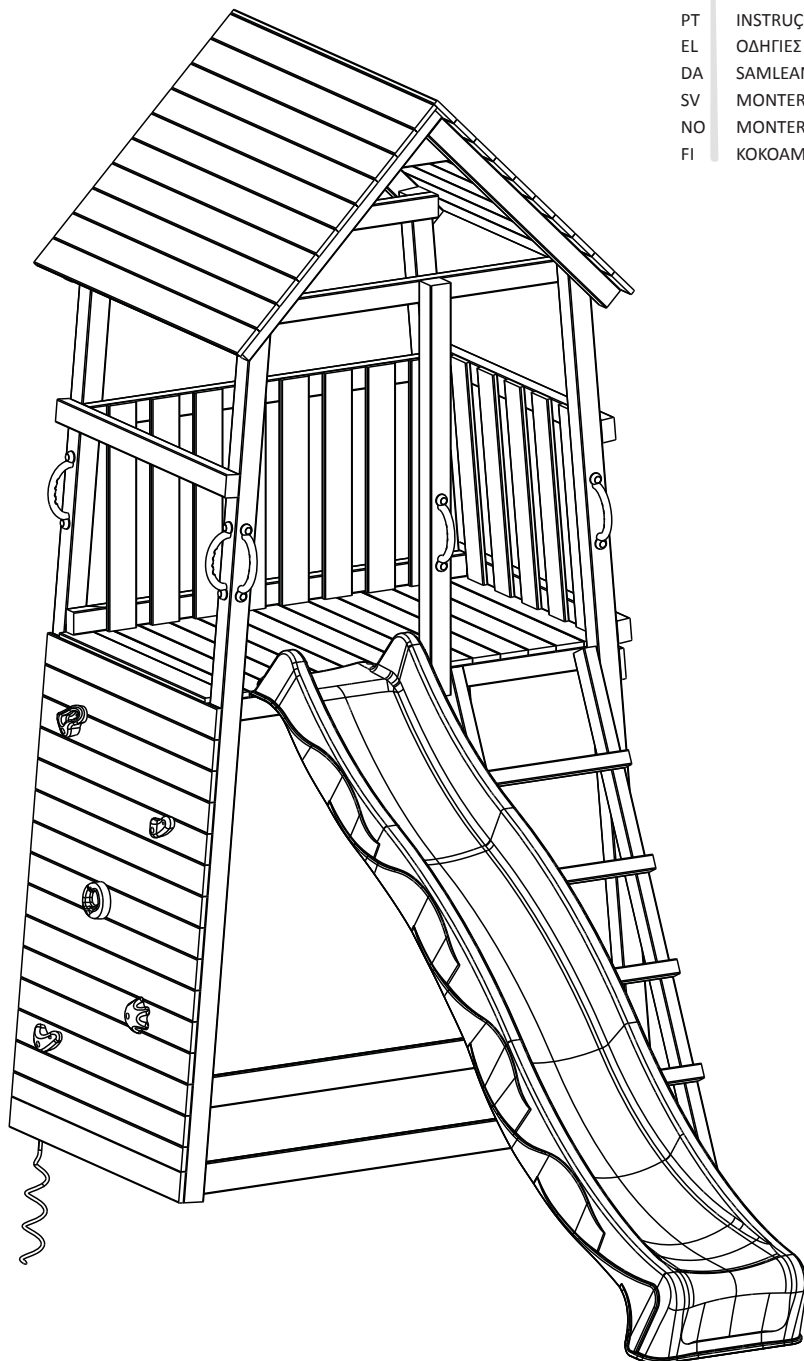

blue rabbit

Belvedere



EN	ASSEMBLY INSTRUCTIONS	PL	INSTRUKCJA MONTAŻU
DE	MONTAGEANLEITUNGEN	CZ	NÁVOD K MONTÁŽI
FR	INSTRUCTIONS DE MONTAGE	SK	MONTÁŽNY NÁVOD
ES	INSTRUCCIONES DE MONTAJE	SI	NAVODILA ZA MONTAŽO
IT	ISTRUZIONI PER L'ASSEMBLAGGIO	HR	UPUTE ZA MONTAŽU
NL	MONTAGE INSTRUCTIES	HU	ÖSSZESZERELÉSI ÚTMUTATÓ
PT	INSTRUÇÕES DE MONTAGEM	RO	INSTRUCȚIUNI DE ASAMBLARE
EL	ΟΔΗΓΙΕΣ ΣΥΝΑΡΜΟΛΟΓΗΣΗΣ	BG	ИНСТРУКЦИЯ ЗА МОНТАЖ
DA	SAMLEANVISNING	LT	MONTAVIMO INSTRUKCIJA
SV	MONTERINGSINSTRUKTIONER	LV	MONTĀŽAS NORĀDĪJUMI
NO	MONTERINGSVEILEDNING	EE	KOKKUPANEMISUHEEND
FI	KOKOAMISOHJEET	RU	ИНСТРУКЦИЯ ПО СБОРКЕ

blue rabbit 2.0















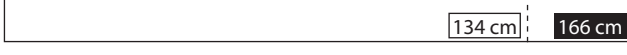



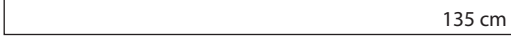



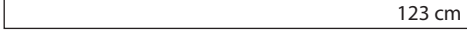



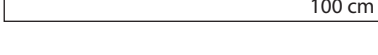

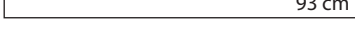

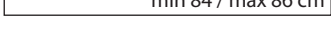



© 2014

Blue Rabbit 2.0 - Hemelrijken 8 - B-2890 St-Amands - Belgium.
Copyrighted material - Do not reproduce under penalty of law.

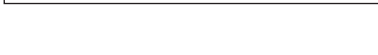

IM008.001.004-v02 (2015-06)

EN 71-1, 2, 3 & 8

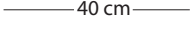
- 4x** **A** min 68 mm max 90 mm  
- 1x** **B** min 68 mm max 90 mm  
- 2x** **C** min 68 mm max 90 mm  
- 1x** **D** min 68 mm max 90 mm  
- 3x** **E** min 68 mm max 90 mm  
- 1x** **F** min 68 mm max 90 mm  
- 1x** **G** min 68 mm max 90 mm  
- 2x** **H** min 68 mm max 90 mm  
- 3x** **I** min 68 mm max 90 mm  
- 2x** **J** min 68 mm max 90 mm  
- 2x** **K** min 68 mm max 90 mm  
- 3x 4x** **L** min 44 mm max 45 mm  
- 2x** **M** min 95 mm max 145 mm  
- 14x*/20x**** **N** ** min 95 mm * max 145 mm  
- 13x*/18x**** **O** ** min 95 mm * max 145 mm  
- 10x*/15x**** **P** ** min 95 mm * max 145 mm  
- 10x*/13x**** **Q** ** min 95 mm * max 145 mm  
- 2x** **R** min 95 mm max 145 mm  

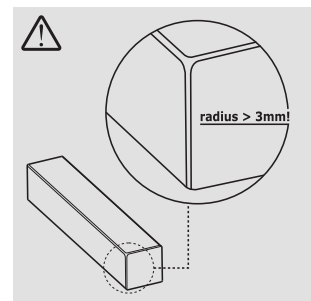
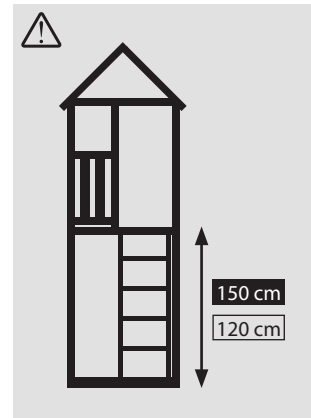

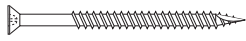
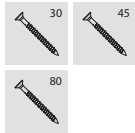

30 mm - 45 mm - 80 mm

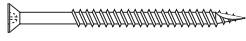
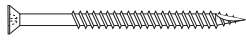

45 mm - 80 mm

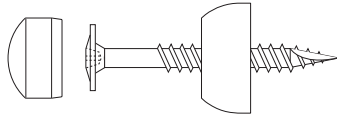

80 mm

4x

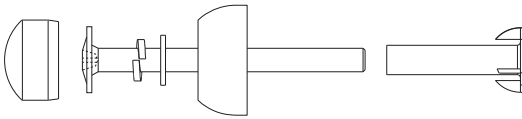

90 / 110 mm

2x

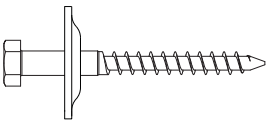

70 mm

5x

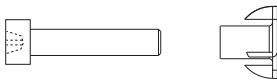

40 mm

5x



30 mm

5x



5x







2x

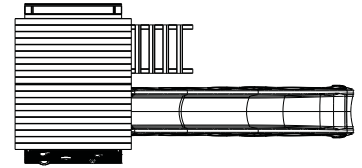
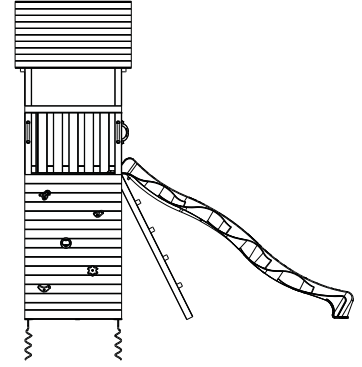
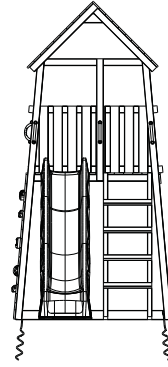
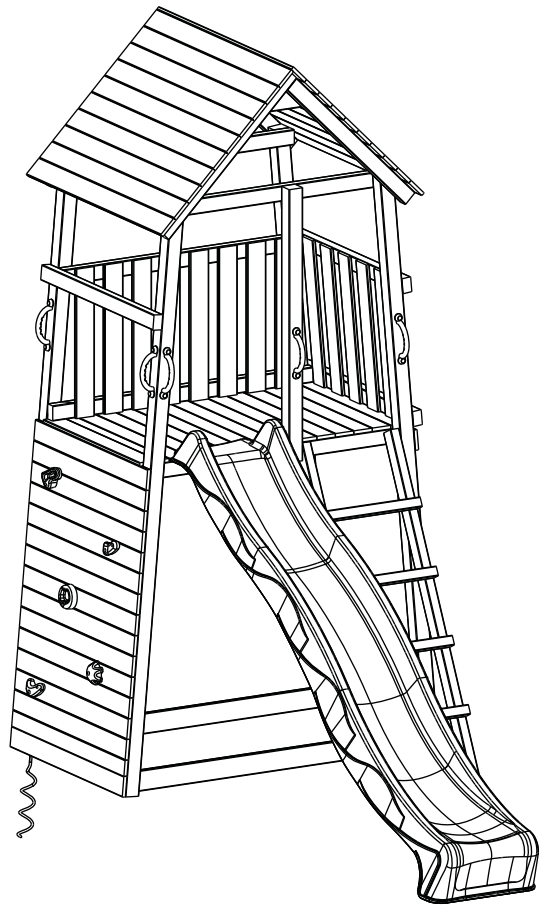

1x



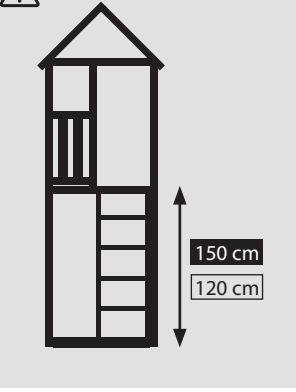
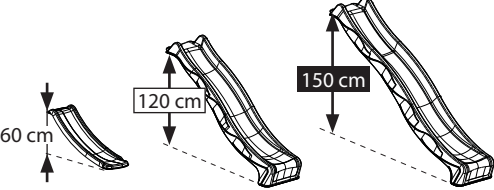
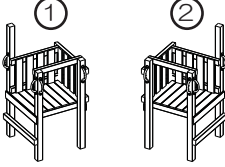

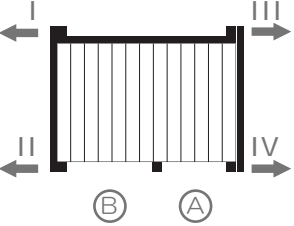
 				@platform 008.003.006.001			@bridge 008.003.004.001
							
Belvedere 008.001.004.001 	150 cm	X	X	Ⓟ	X	X	X
	120 cm	X	Ⓟ	X	X	X	X

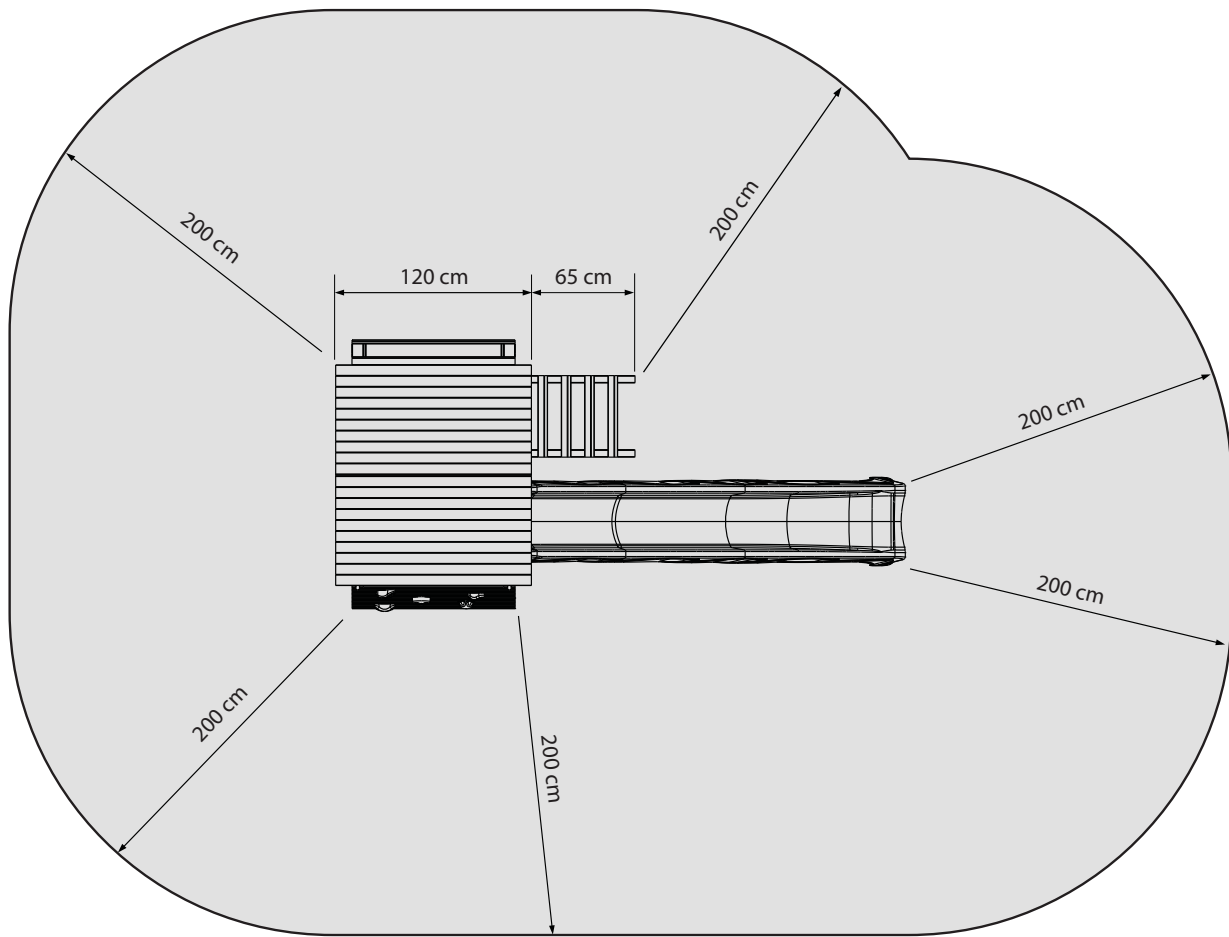

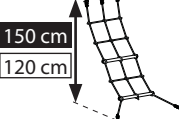
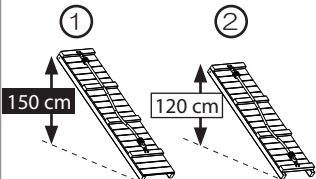
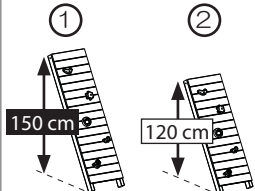
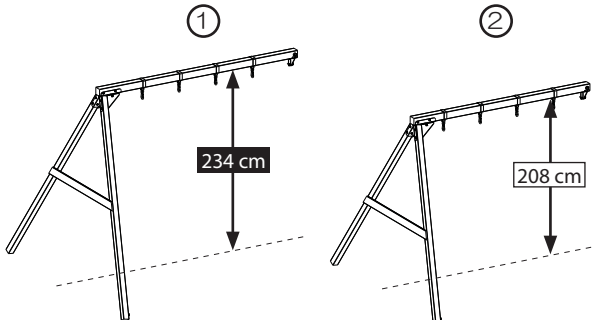
@net 008.003.003.001	@ramp 008.003.002.001		@wall 008.003.001.001		@swing 008.003.005.001	
						
(A)	(A)	X	(A)	X	III → IV →	X
(A)	X	(A)	X	(A)	X	III → IV →

ERFORDERLICHES WERKZEUG

- (1) Universalschraubenschlüssel mit Aufsatz 13
- (2) Maßband
- (3) Bleistift
- (4) Bohrer Torx TX20
- (5) Bohrer Torx TX30
- (6) Bohrer Torx TX40
- (7) Bohr- und/oder Schraubmaschine
- (8) Winkelmass
- (9) Holzbohrer, Durchmesser 3 und 5 mm
- (10) Speedbohrer, Durchmesser 10 und 28 mm
- (11) Holzsäge
- (12) Hammer
- (13) Schleifpapier

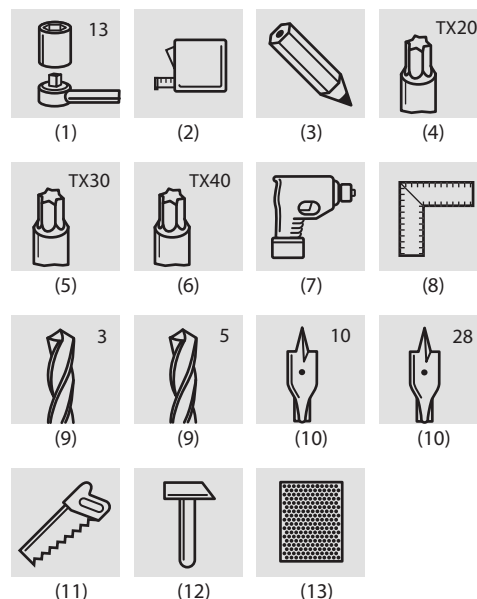

HOLZSCHRAUBEN

Schritt 1/ Um zu vermeiden, dass sich das Holz spaltet, empfehlen wir, alle zu schraubenden Holzteile vorzubohren. Bohren Sie immer mindestens 15 mm weniger tief als die Schraube lang ist. Holzschrauben mit einem Durchmesser von 4,5 mm bohren Sie mit einem Holzbohrer von 3 mm vor.

Schritt 2/ Drehen Sie die Schraube zuerst einige Millimeter in das zu befestigende Brett, und drücken Sie dies danach kräftig gegen das andere Holz.

Schritt 3/ Drehen Sie die Schraube mit dem mitgelieferten Bohrer torx TX20 in das Holz, bis der Kopf der Schraube auf gleicher Höhe mit dem Holz ist.

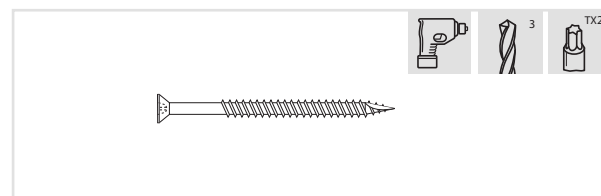

VIERKANT-HOLZSCHRAUBEN

Schritt 1/ Um zu vermeiden, dass sich das Holz spaltet, empfehlen wir, alle zu schraubenden Holzteile vorzubohren. Bohren Sie immer mindestens 15 mm weniger tief, als die Schraube lang ist. Vierkant-Holzschrauben mit einem Durchmesser von 8 mm bohren Sie mit einem Holzbohrer von 5 mm vor.

Schritt 2/ Bringen Sie die Unterlegscheibe und den untersten Teil der Abdeckkappe über dem Schaft der Schraube an.

Schritt 3/ Drehen Sie die Schraube zuerst einige Millimeter in den zu befestigenden Balken, und drücken Sie diesen danach kräftig gegen das andere Holz.

Schritt 4/ Ziehen Sie die Schraube mit der mitgelieferten Bohrer torx TX40 an.

Schritt 5/ Drücken Sie die Kappe der Abdeckkappe in die vorgesehene Öffnung.

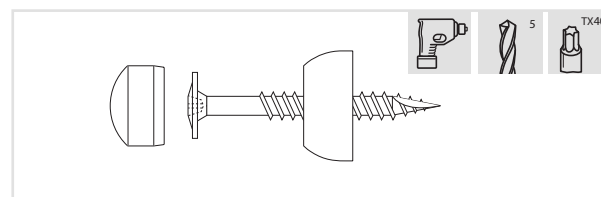

SCHRAUBVERBINDUNGEN

Schritt 1/ Bohren Sie ein Loch mit einem Durchmesser von 10 mm durch beide bereits aneinander geschraubte Bretter oder Balken (siehe 'Holzschrauben').

Schritt 2/ Schlagen Sie die Druckmutter mit einem Hammer entlang der angegebene Seite des Balkens in das Loch.

Schritt 3/ Bringen Sie den Federring, die Unterlegscheibe und danach den untersten Teil der Abdeckkappe über dem Schaft der Schraube an.

Schritt 4/ Schieben Sie die Schraube durch das Loch, und drehen Sie mit der Hand einige Umdrehungen, bis sich die Schraube zügig in die Druckmutter reht.

Schritt 5/ Ziehen Sie die Schraube mit der mitgelieferten Bohrer torx TX40 an, bis der Federring zwischen dem Kopf der Schraube und der Unterlegscheibe vollständig flachgedrückt ist.

Schritt 6/ Drücken Sie die Kappe der Abdeckkappe in die vorgesehene Öffnung.

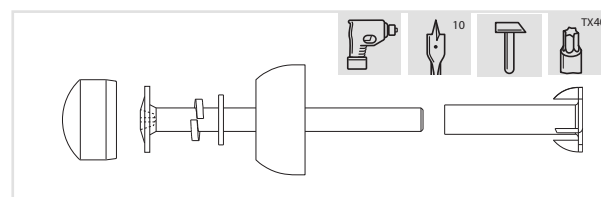

OUTILLAGE NÉCESSAIRE

- (1) clé à cliquet avec douille 13
- (2) mètre roulant
- (3) crayon
- (4) tournevis torx TX20
- (5) tournevis torx TX30
- (6) tournevis torx TX40
- (7) foreuse et / ou visseuse
- (8) équerre
- (9) mèches à bois Ø 3 et Ø 5 mm
- (10) mèches foret Ø 10 et Ø 28 mm
- (11) scie à bois
- (12) marteau
- (13) papier émeri

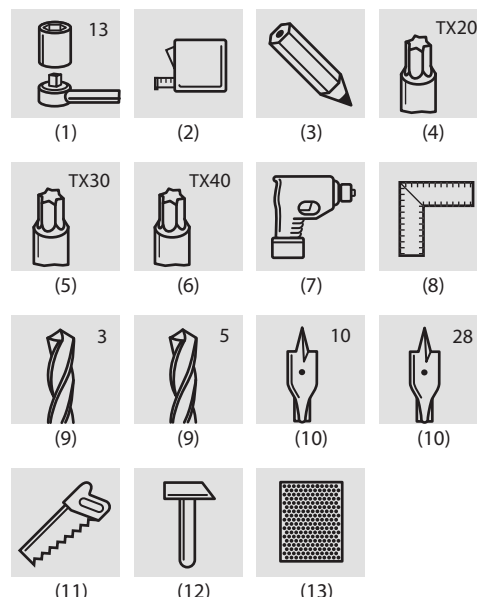

VIS À BOIS

étape 1/ Pour éviter que le bois ne se fende, nous conseillons de forer préalablement tout le bois à visser. La profondeur de forage doit être inférieure d'au moins 15 mm à la longueur de la vis. Les vis à bois de 4,5 mm de diamètre doivent être forées préalablement avec une mèche à bois de 3 mm.
 étape 2/ Commencez par tourner la vis de quelques millimètres dans la planche à fixer. Pressez ensuite fermement cette planche contre l'autre bois.
 étape 3/ Enfoncez la vis dans le bois avec le tournevis torx TX20 fourni, jusqu'à ce que la tête de la vis soit au même niveau que le bois.

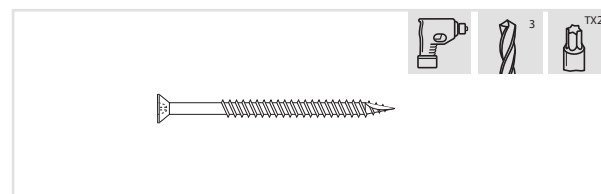

TIRE-FOND

étape 1/ Pour éviter que le bois ne se fende, nous conseillons de forer préalablement tout le bois à visser. La profondeur de forage doit être inférieure d'au moins 15 mm à la longueur de la vis. Les tire-fonds de 8 mm de diamètre doivent être forés préalablement avec une mèche à bois de 5 mm.
 étape 2/ Placez la rondelle plate et la partie inférieure du cache-écrou sur la tige de la vis.
 étape 3/ Commencez par tourner la vis de quelques millimètres dans la poutre à fixer. Pressez ensuite fermement cette poutre contre l'autre bois.
 étape 4/ Enfoncez la vis avec le tournevis torx TX40 fourni.
 étape 5/ Enfoncez la petite coiffe du cache-écrou dans l'ouverture prévue.

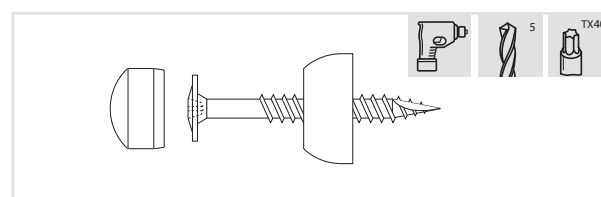

BOULONS

étape 1/ Forez un trou de 10 mm de diamètre à travers les deux planches ou poutres déjà vissées l'une à l'autre (voir « vis à bois »).
 étape 2/ Enfoncez l'écrou à presser dans le trou avec un marteau, sur le côté désigné de la poutre.
 étape 3/ Placez la bague à ressort, la rondelle plate et, enfin, la partie inférieure du cache-écrou sur la tige du boulon.
 étape 4/ Enfoncez le boulon dans l'orifice puis tournez quelques fois manuellement jusqu'à ce que le boulon tourne parfaitement dans l'écrou à presser.
 étape 5/ Enfoncez le boulon avec le tournevis torx TX40 fourni, en tournant jusqu'à ce que la bague à ressort soit entièrement enfoncée entre la tête du boulon et la rondelle plate.
 étape 6/ Enfoncez la petite coiffe du cache-écrou dans l'ouverture prévue.

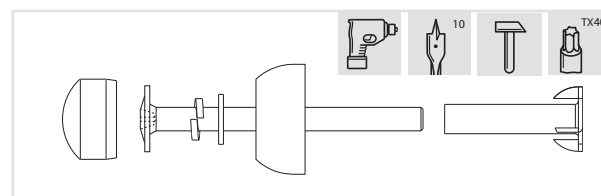

1a

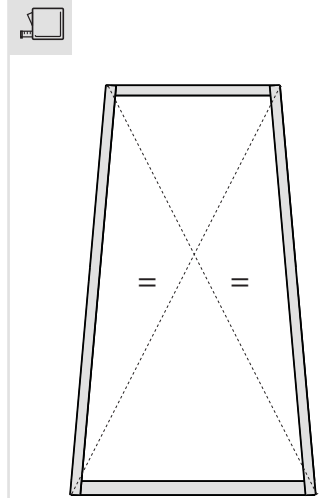
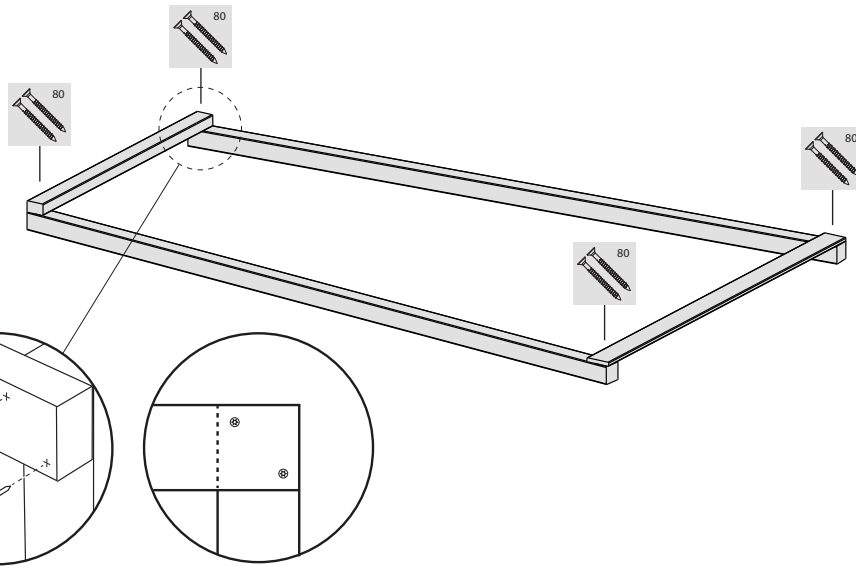
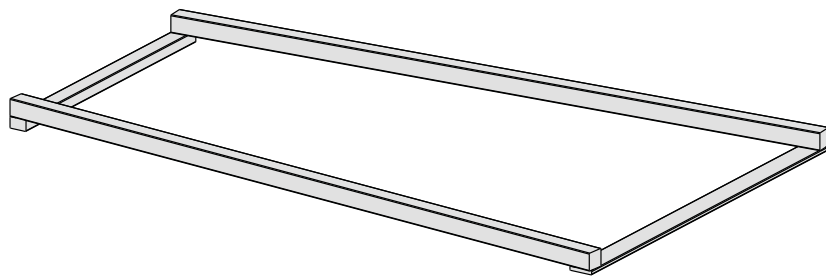

- A** 4x
- H** 2x
- M** 2x
-  8x



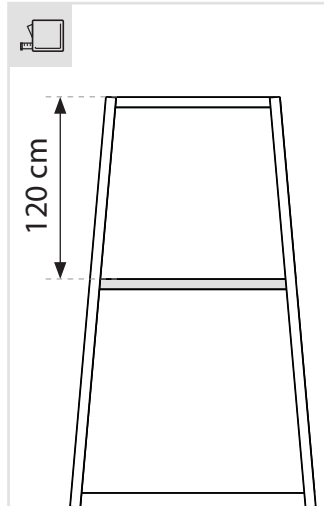
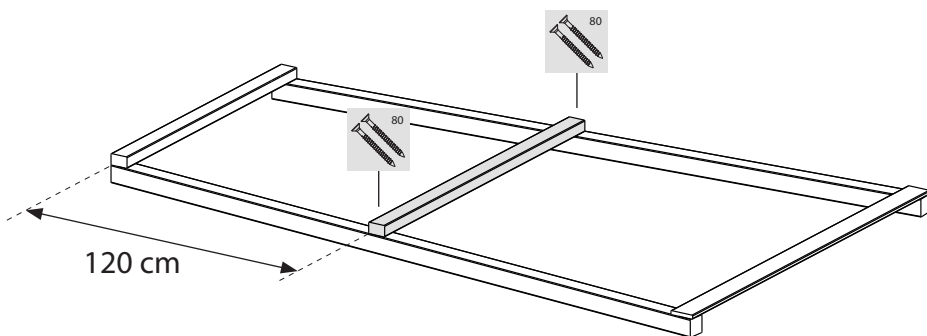
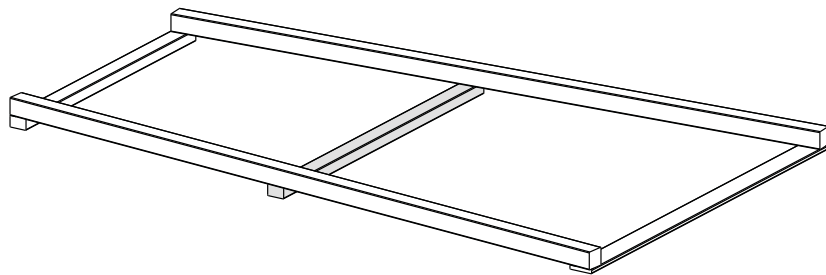

1b

- E** 2x
-  4x

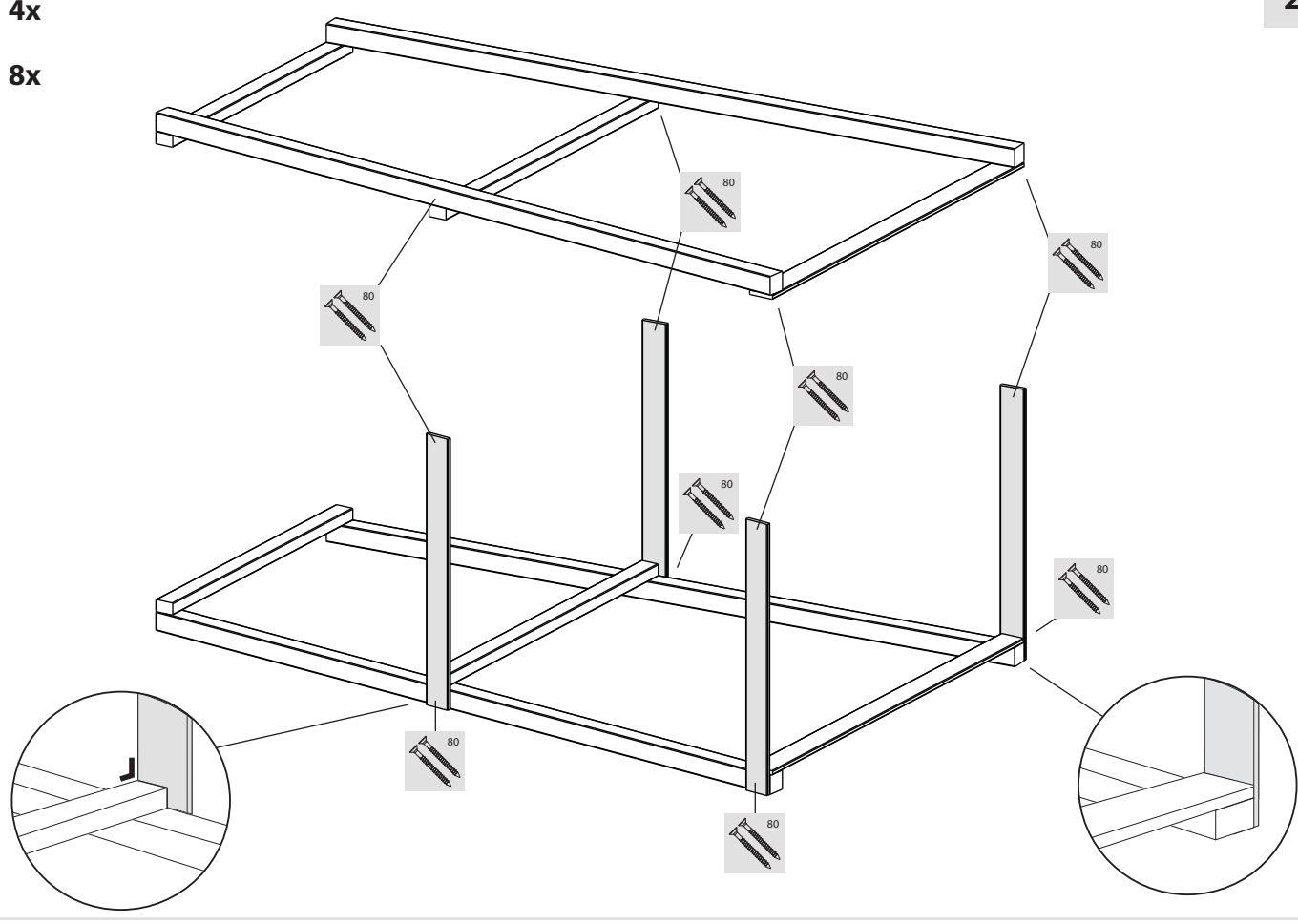

-  4x
-  8x 8x



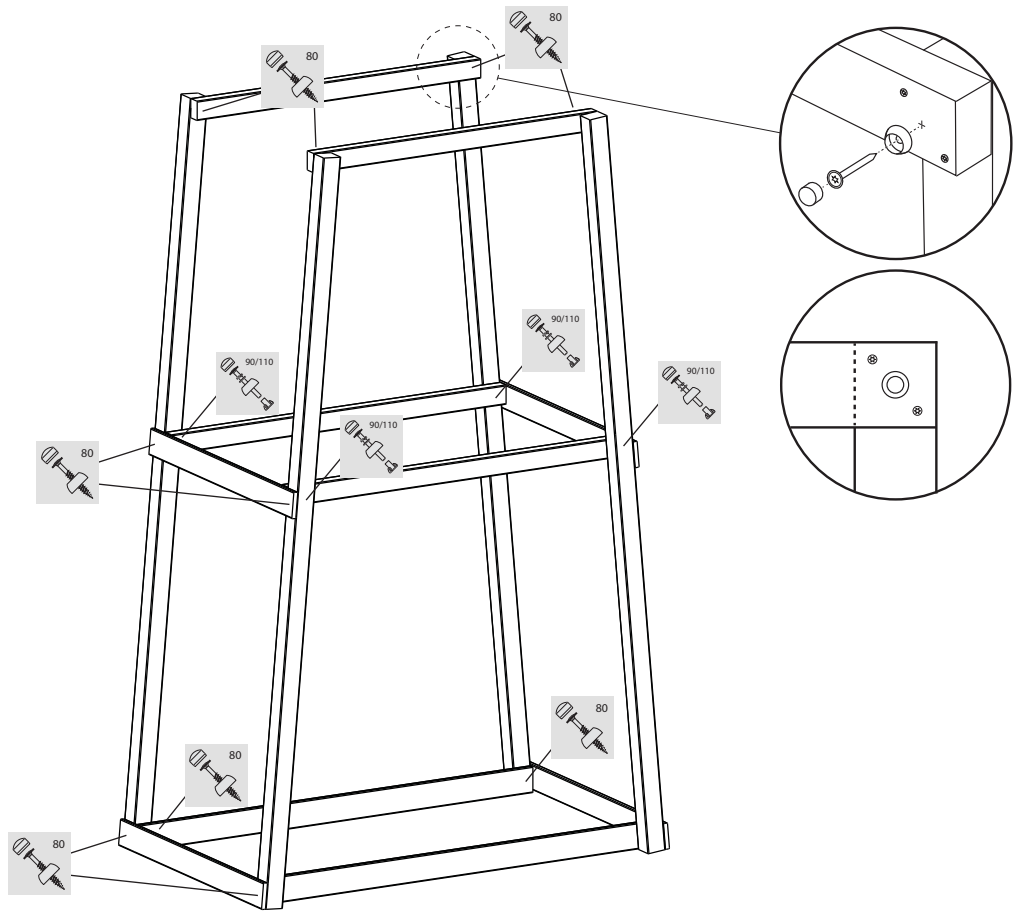

-  8x 16x
-  90/110 4x

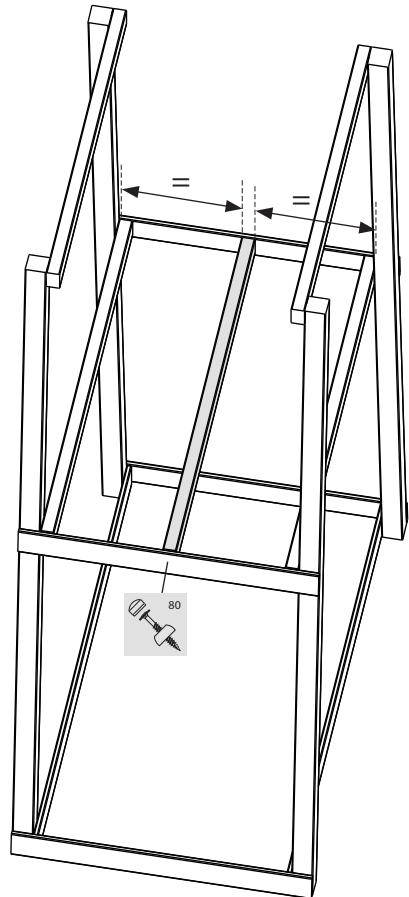

-  1x
-  80 2x



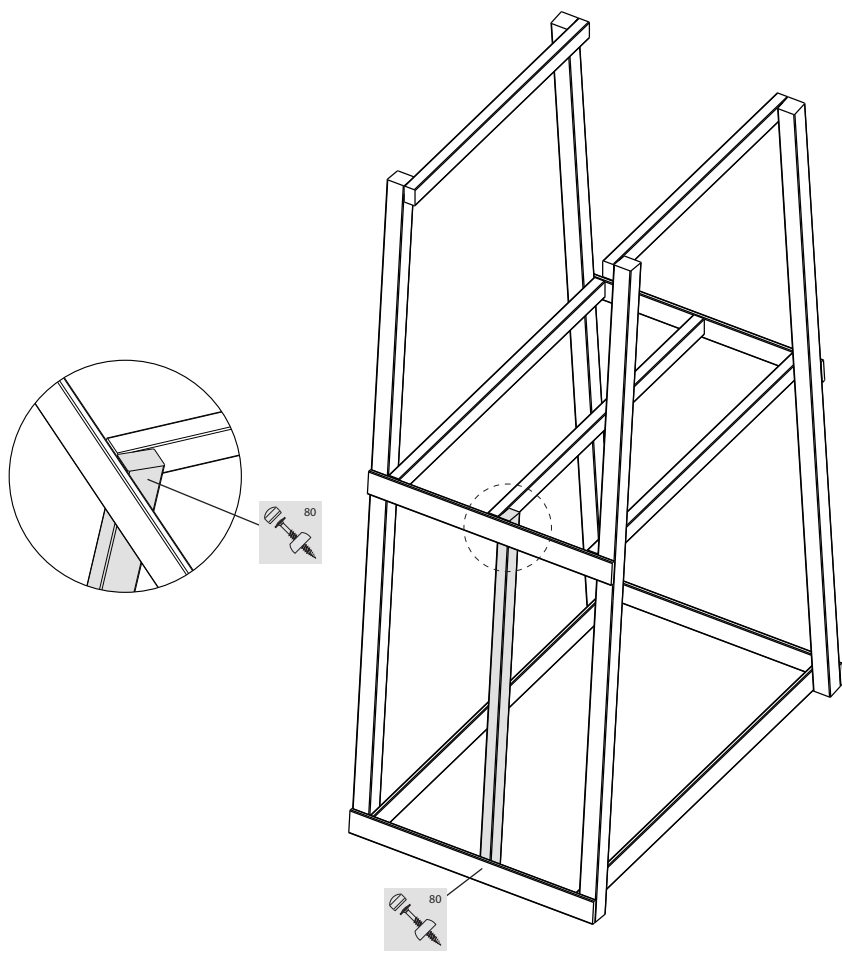

-  1x
-  80 2x

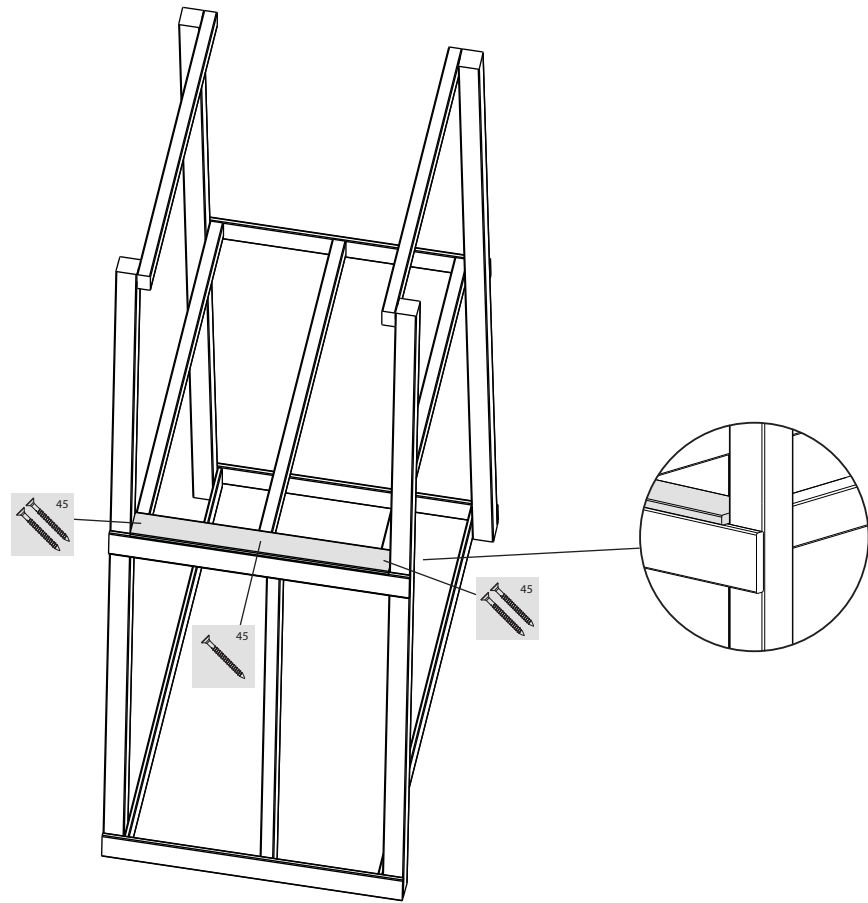

-  **1x**
-  **2x**
-  **1x**



-  **8x/13x**
-  **26x**
-  **13x**

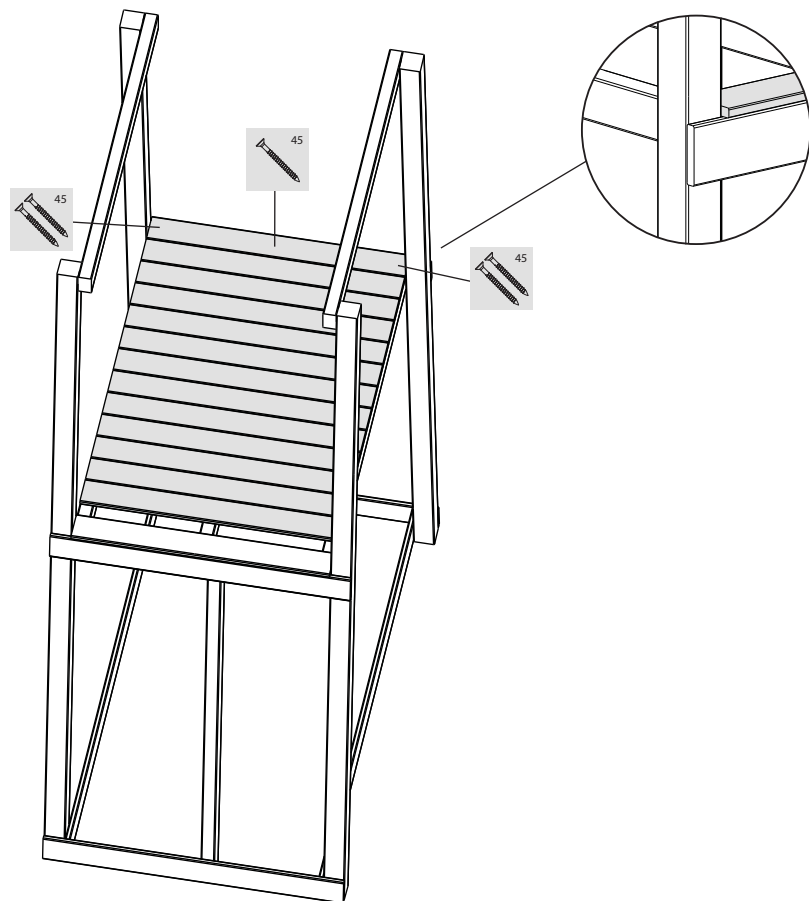

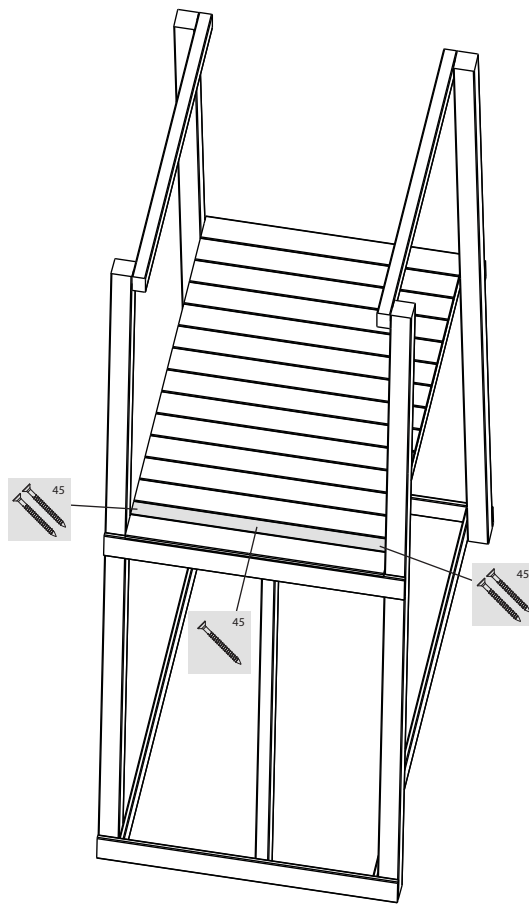
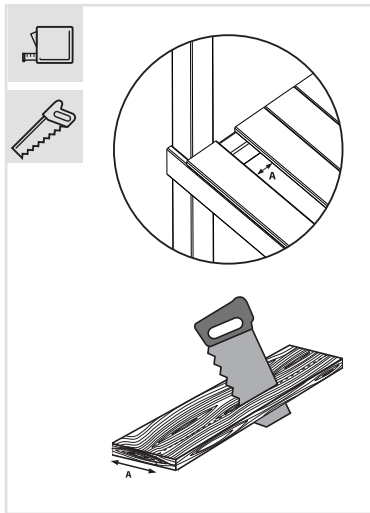

-  **1x**
-  **2x**
-  **1x**

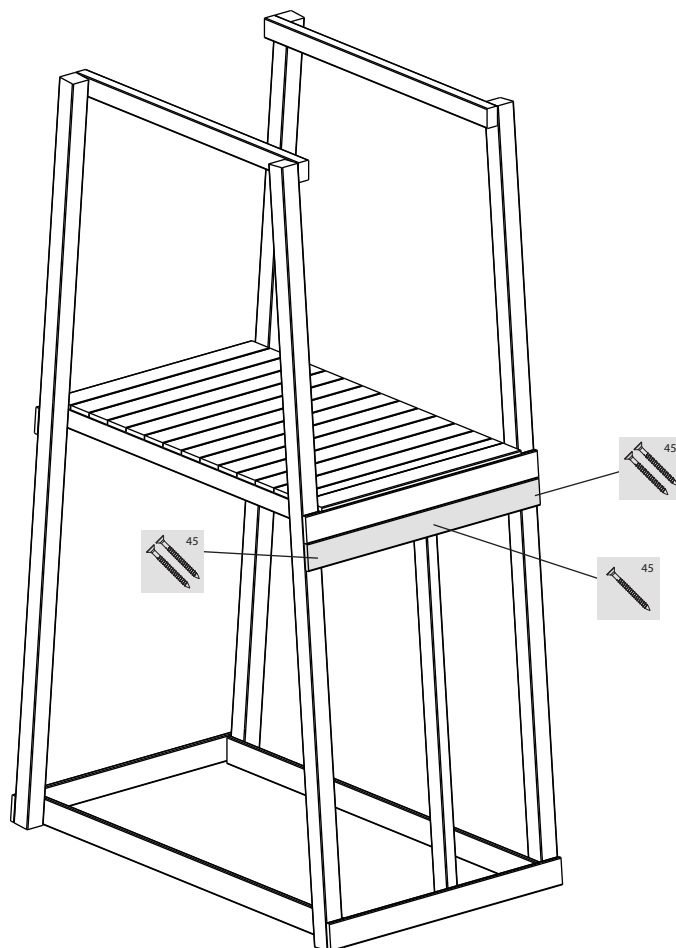

-  **1x**
-  **2x**
-  **1x**



-  **7x/12x**
-  **24x**
-  **12x**

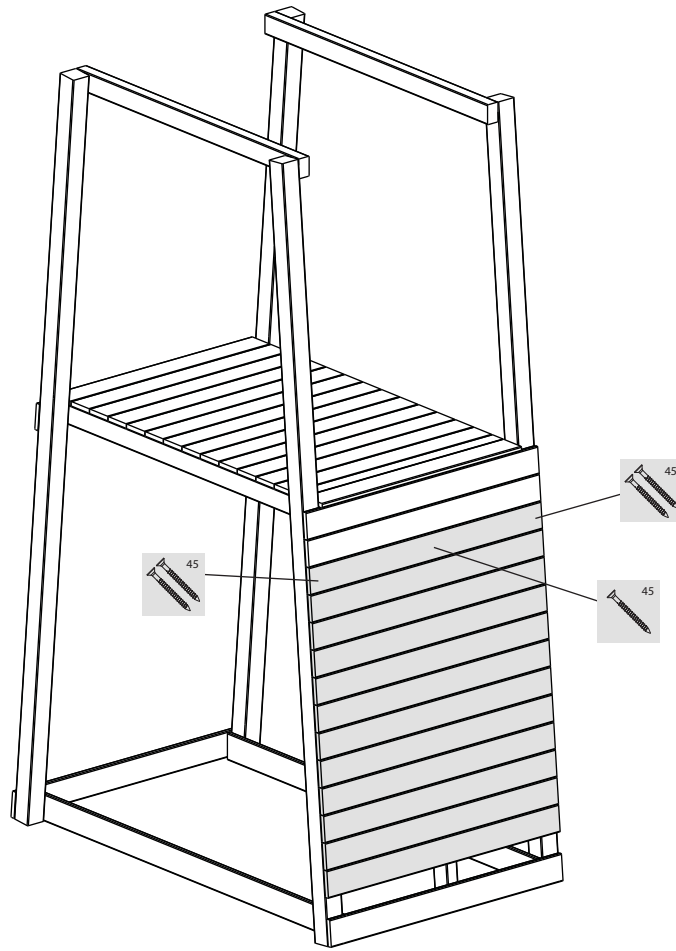

-  **1x**
-  **2x**
-  **1x**

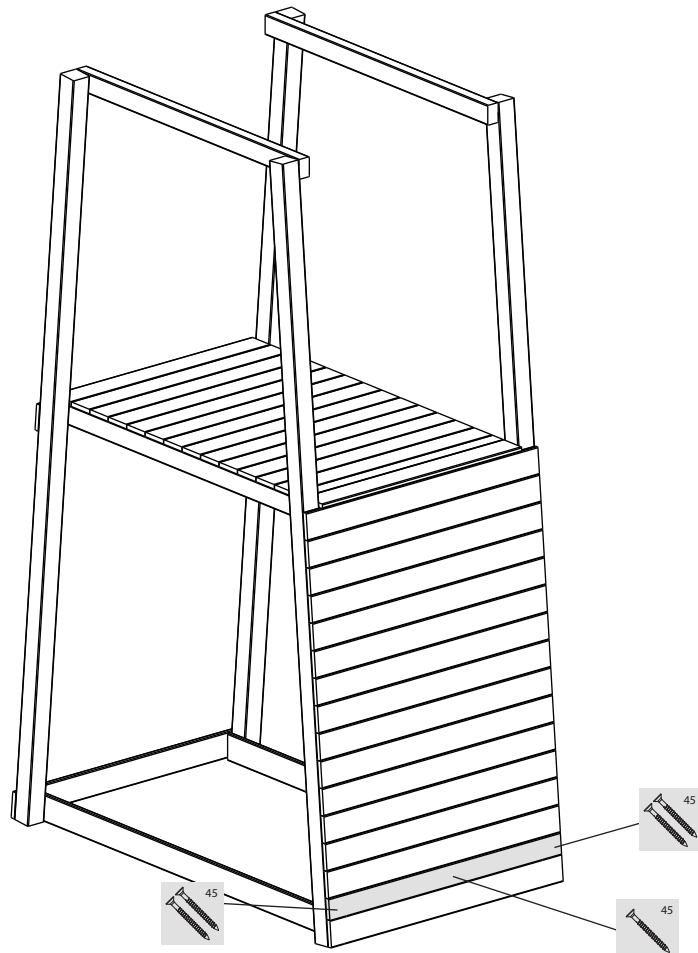
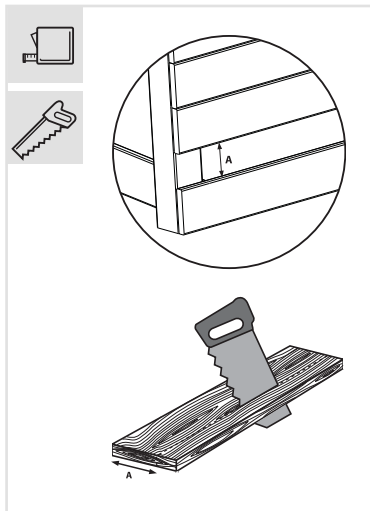

- C** 2x
- L** 3x 4x
-  80 **8x**

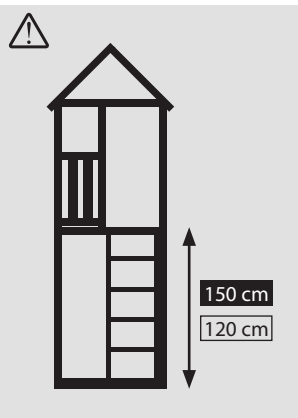
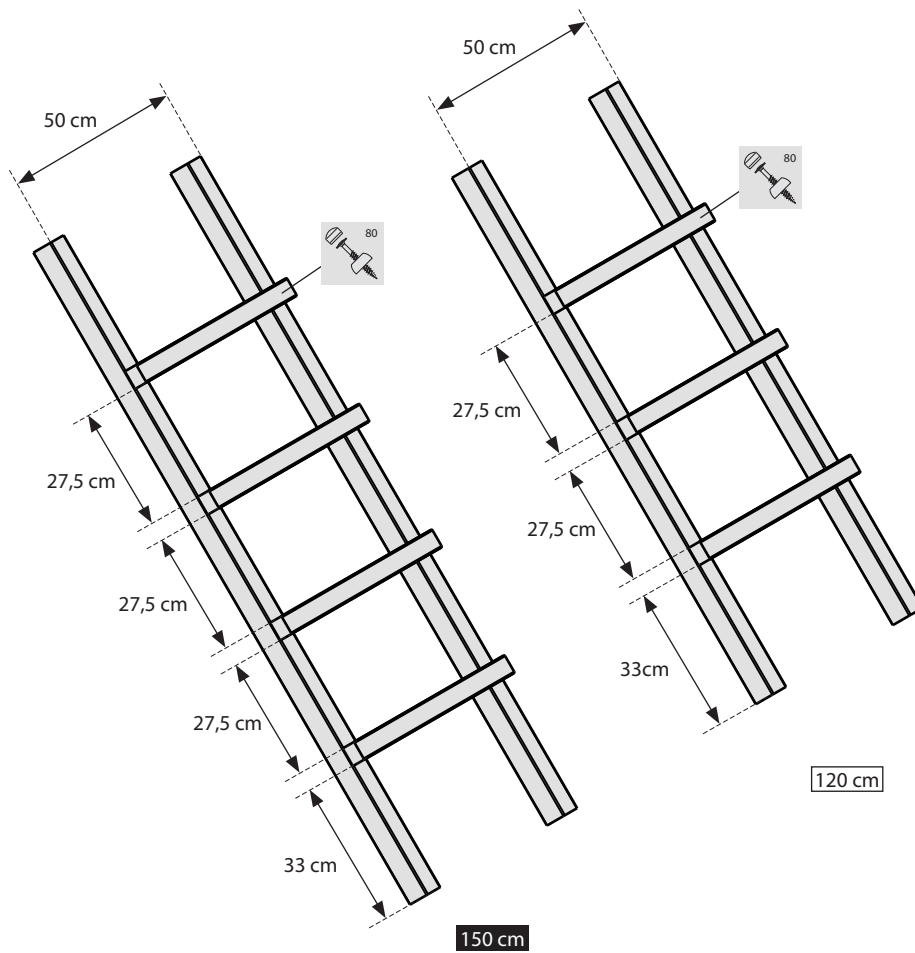

-  80 **1x**

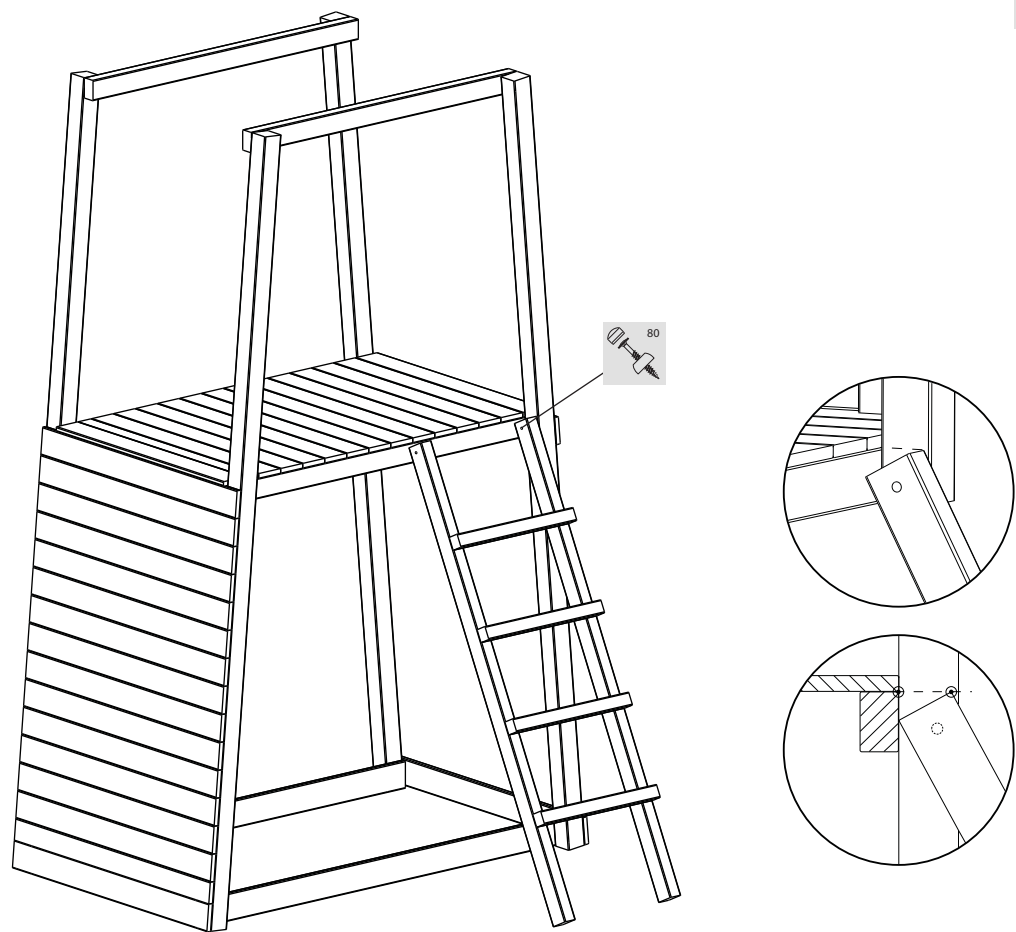

- B** 1x
-  80 3x

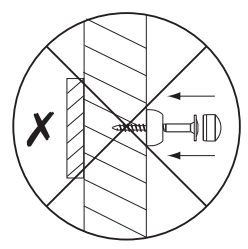
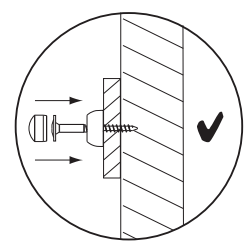
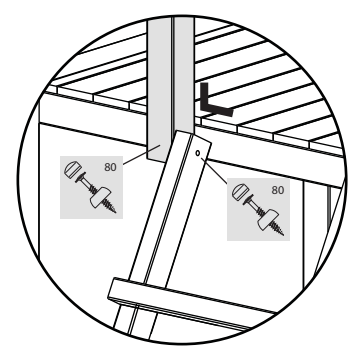
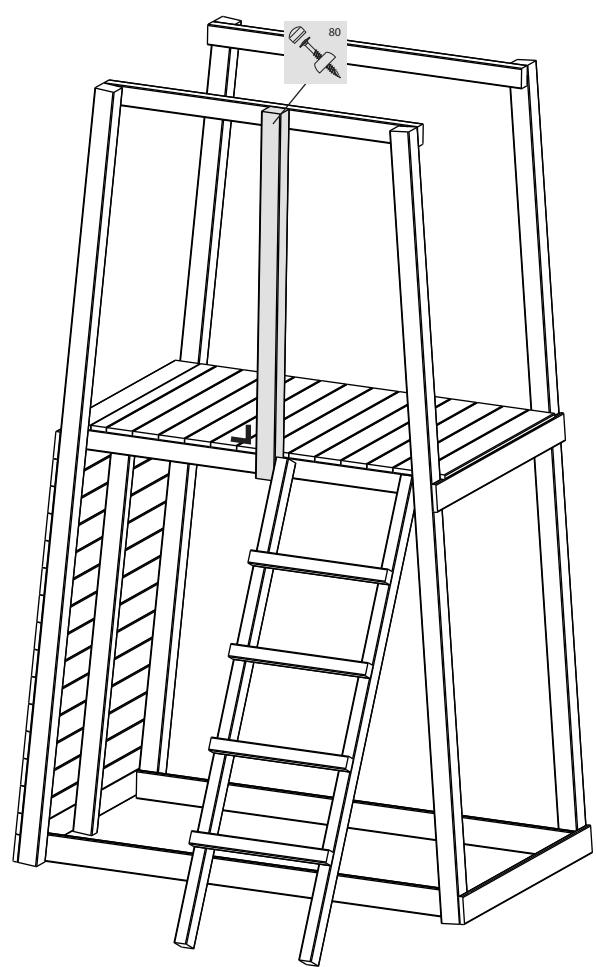

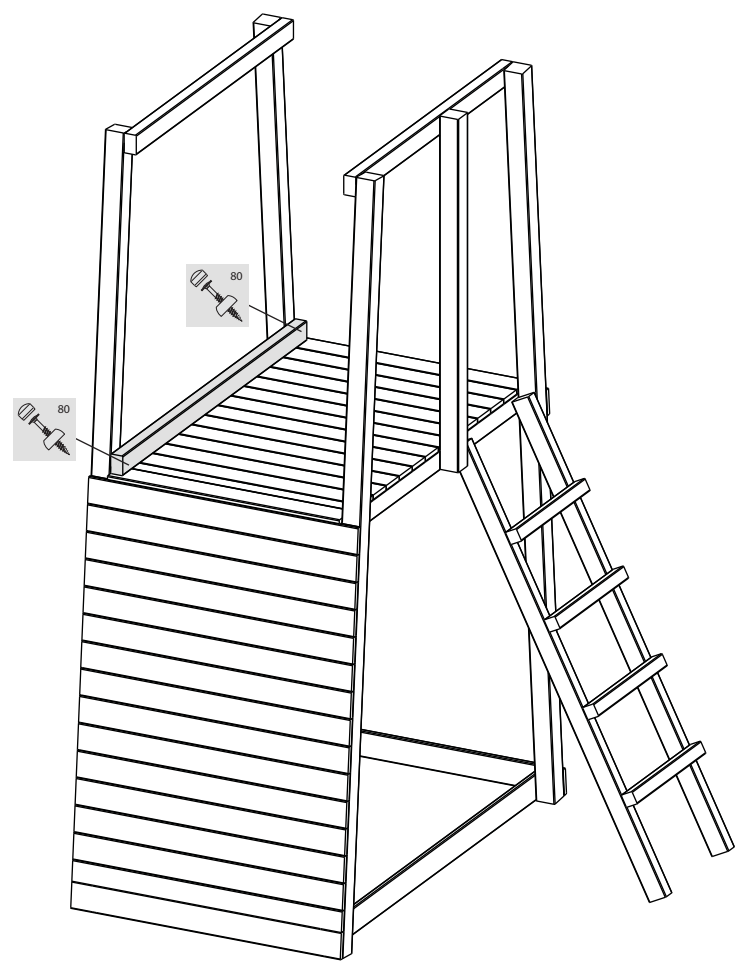

- F** 1x
-  80 2x

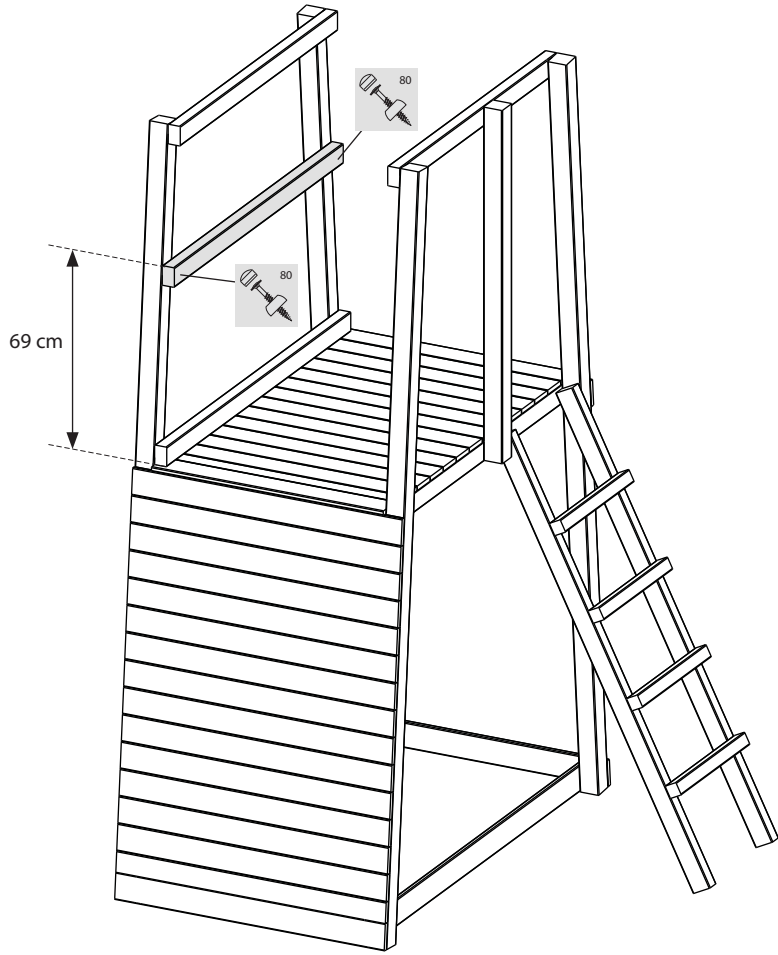

-  1x
-  2x



-  1x
-  2x

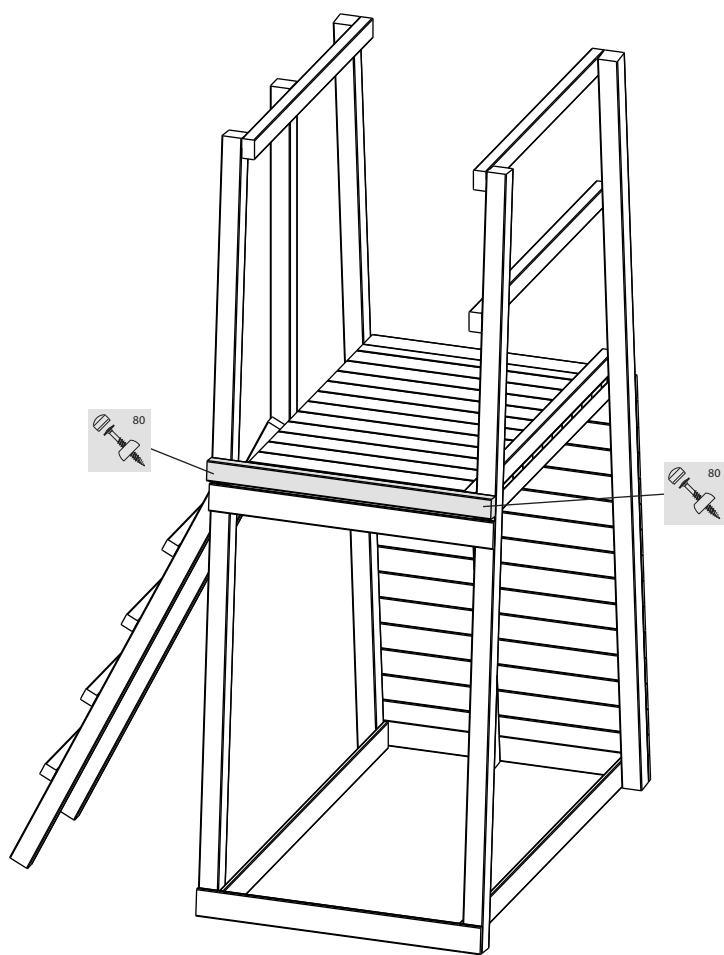

- 1x
- 2x

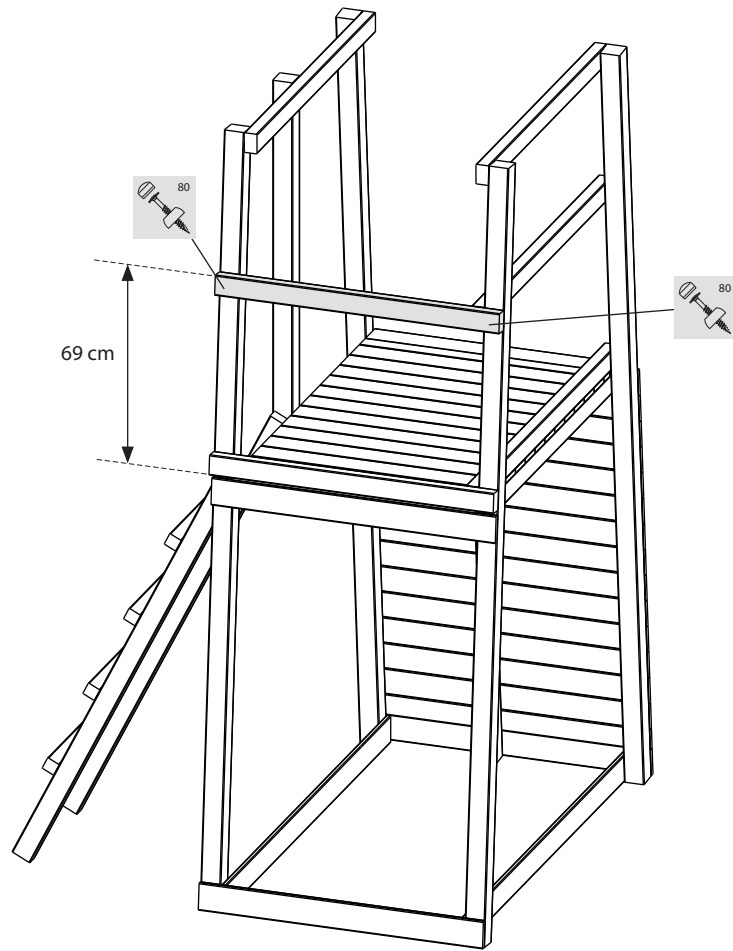

10d



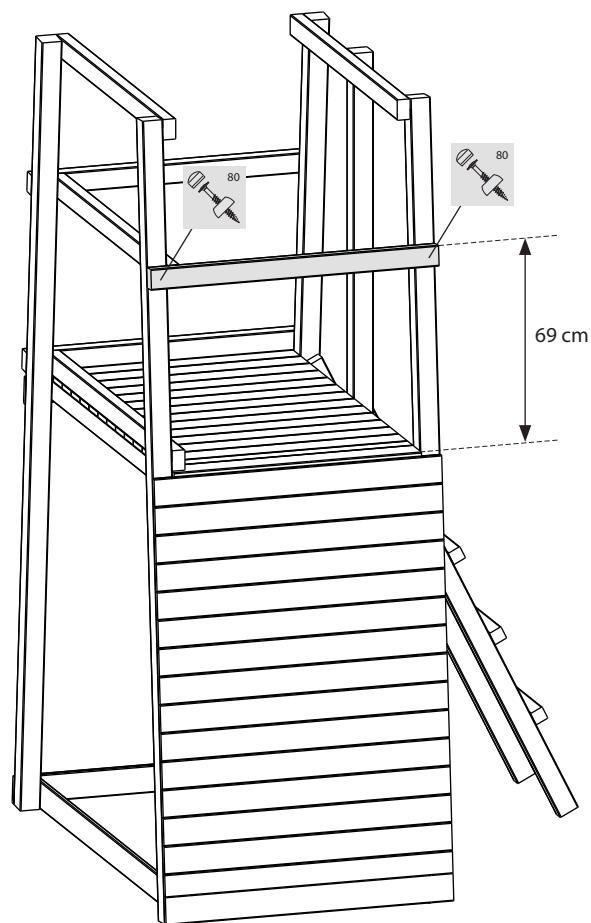

- 1x
- 2x

10e



 **4x/5x**
 **10x**



 **6x/8x**
 **16x**

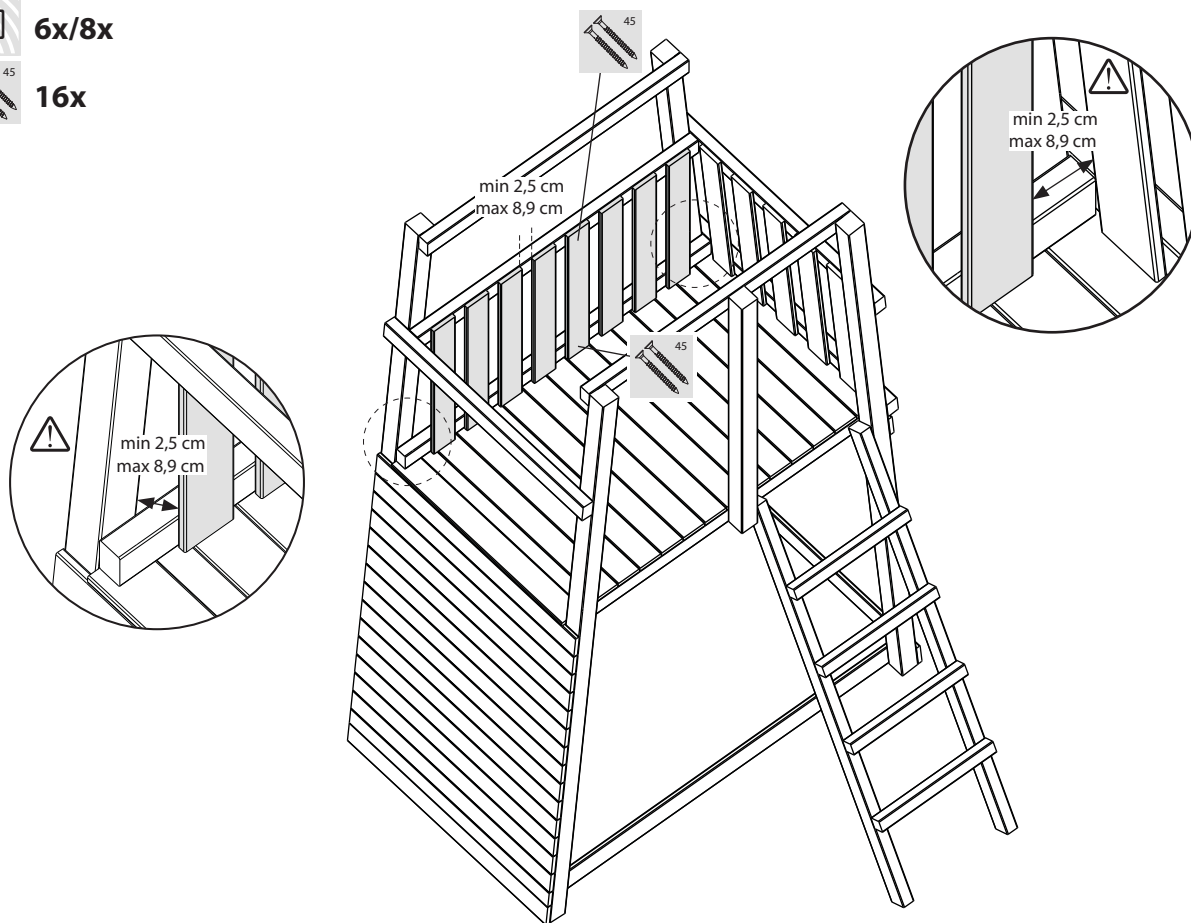

-  **2x**
-  **2x**
-  **2x**
-  **12x**

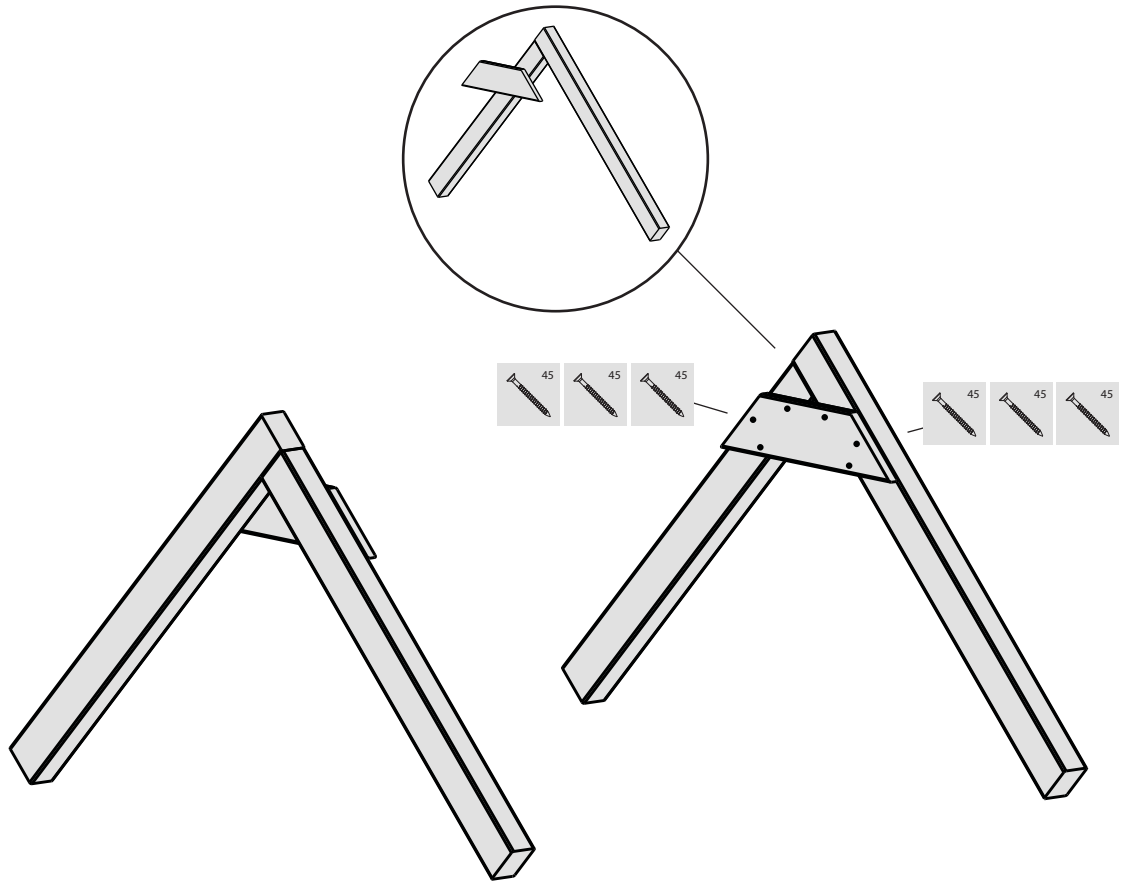



-  **2x**
-  **2x**

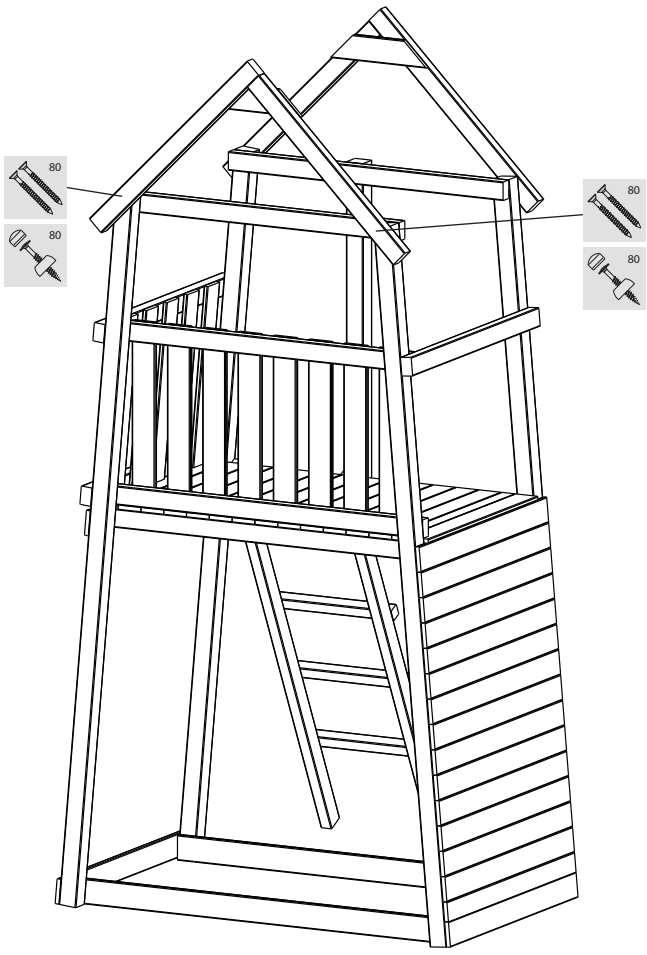

-  2x
-  2x



-  1x
-  2x

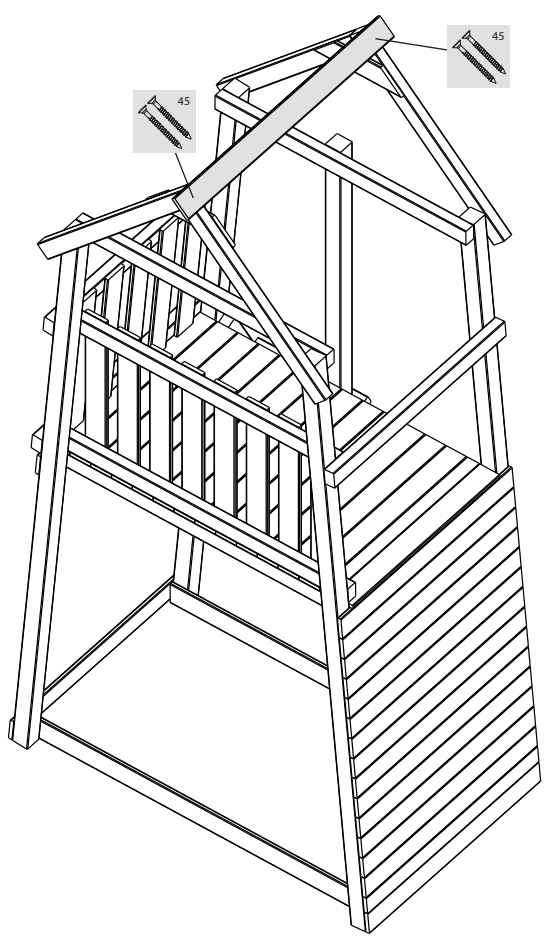

N 6x/9x
45 18x

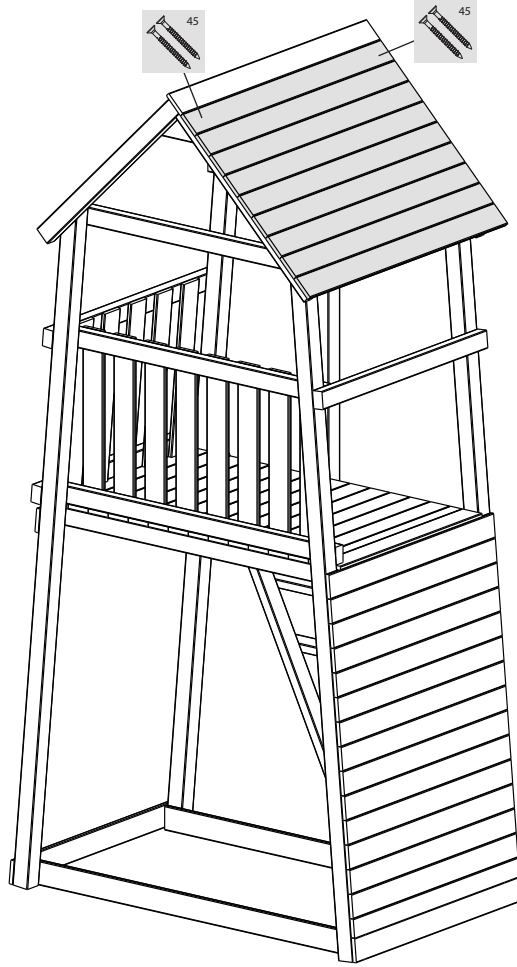

N 1x
45 2x

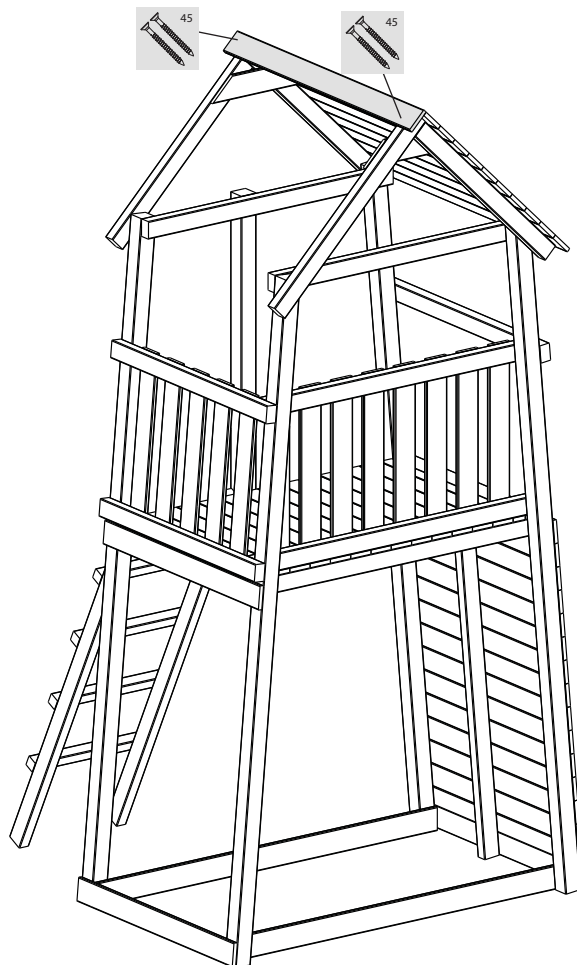

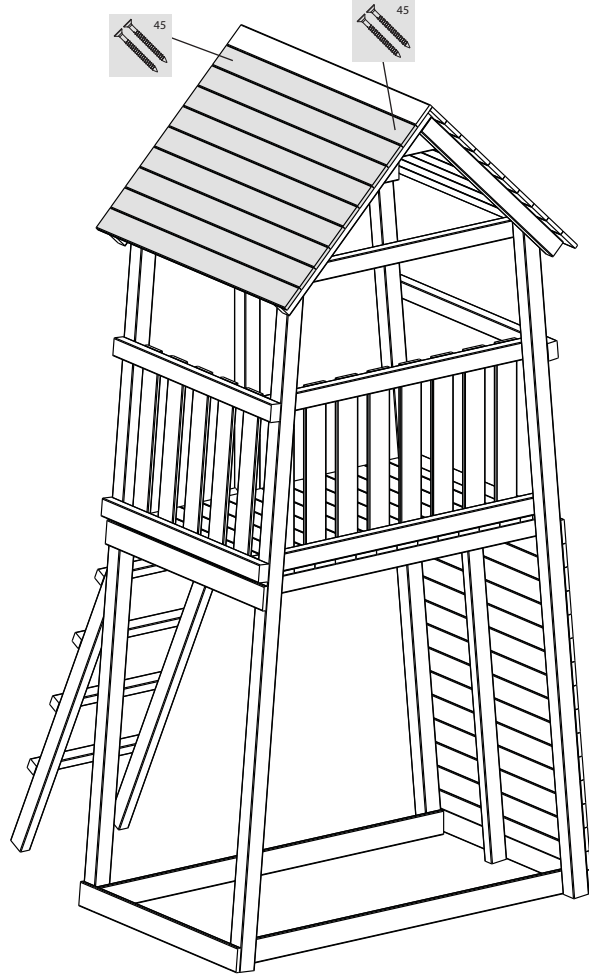

N 6x/9x
45 18x

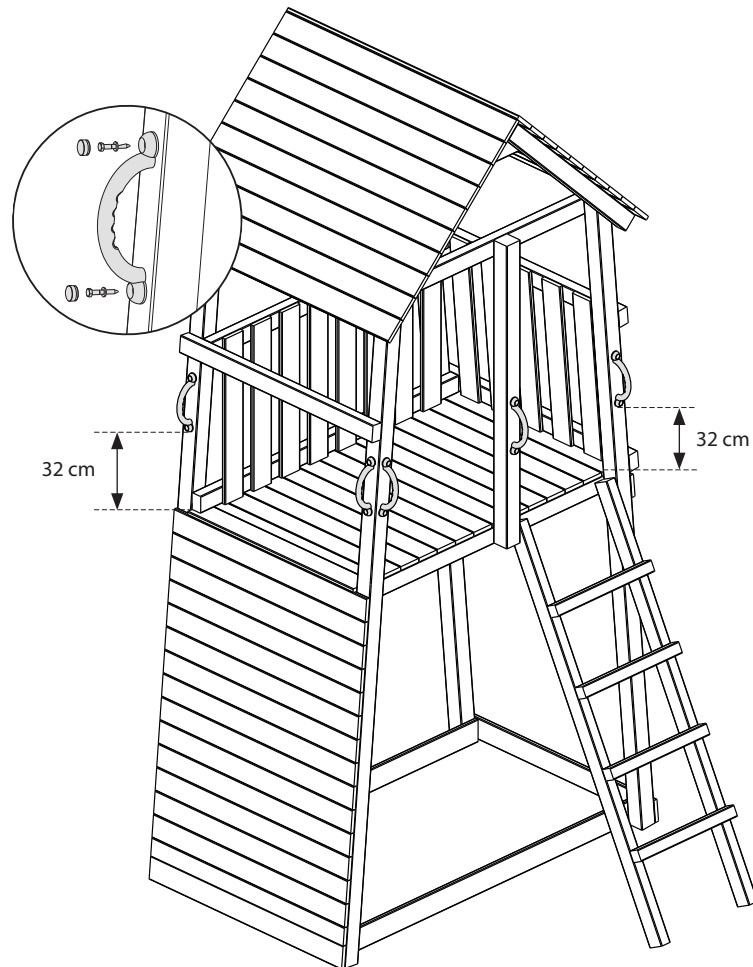

5x



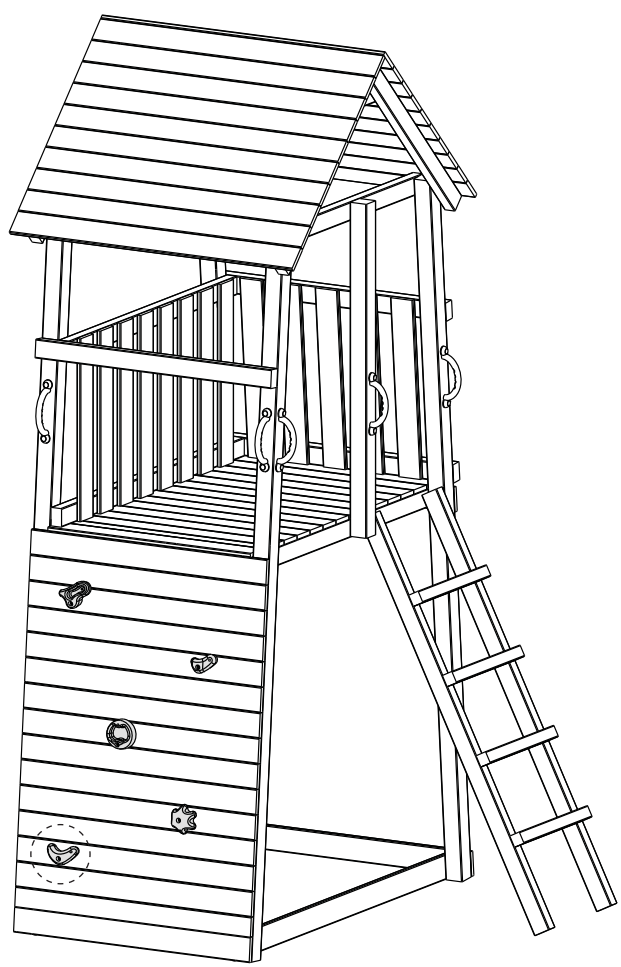
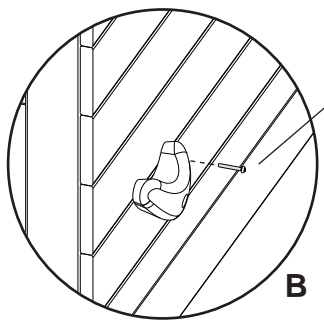
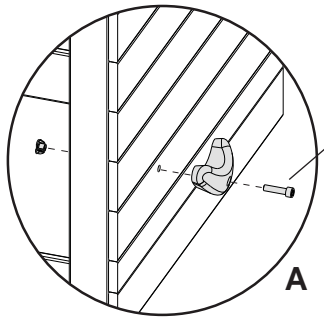

-  5x
-  5x
-  5x

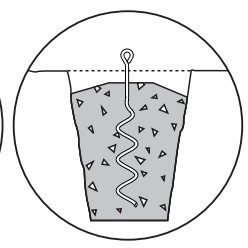
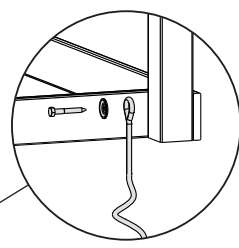
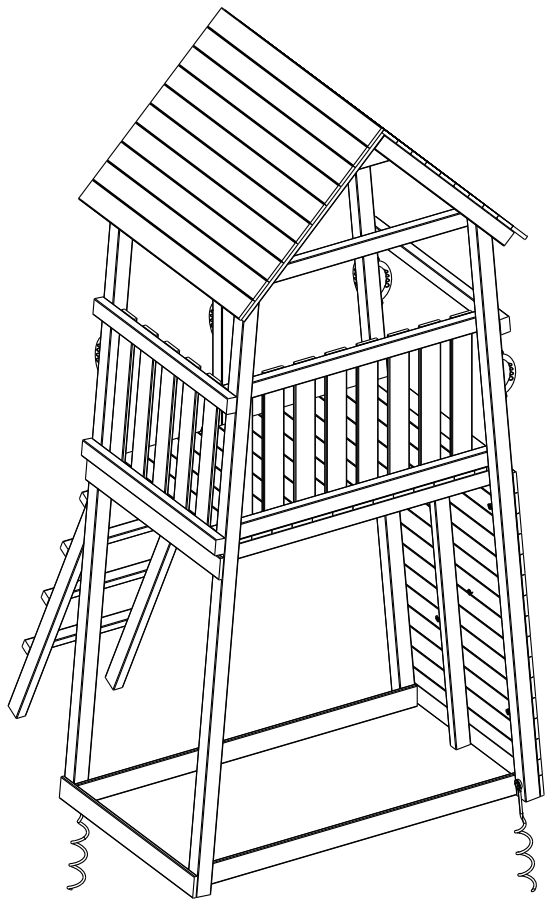

-  2x
-  2x



-  1x
-  2x

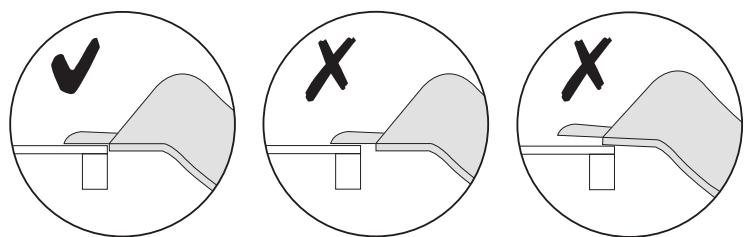
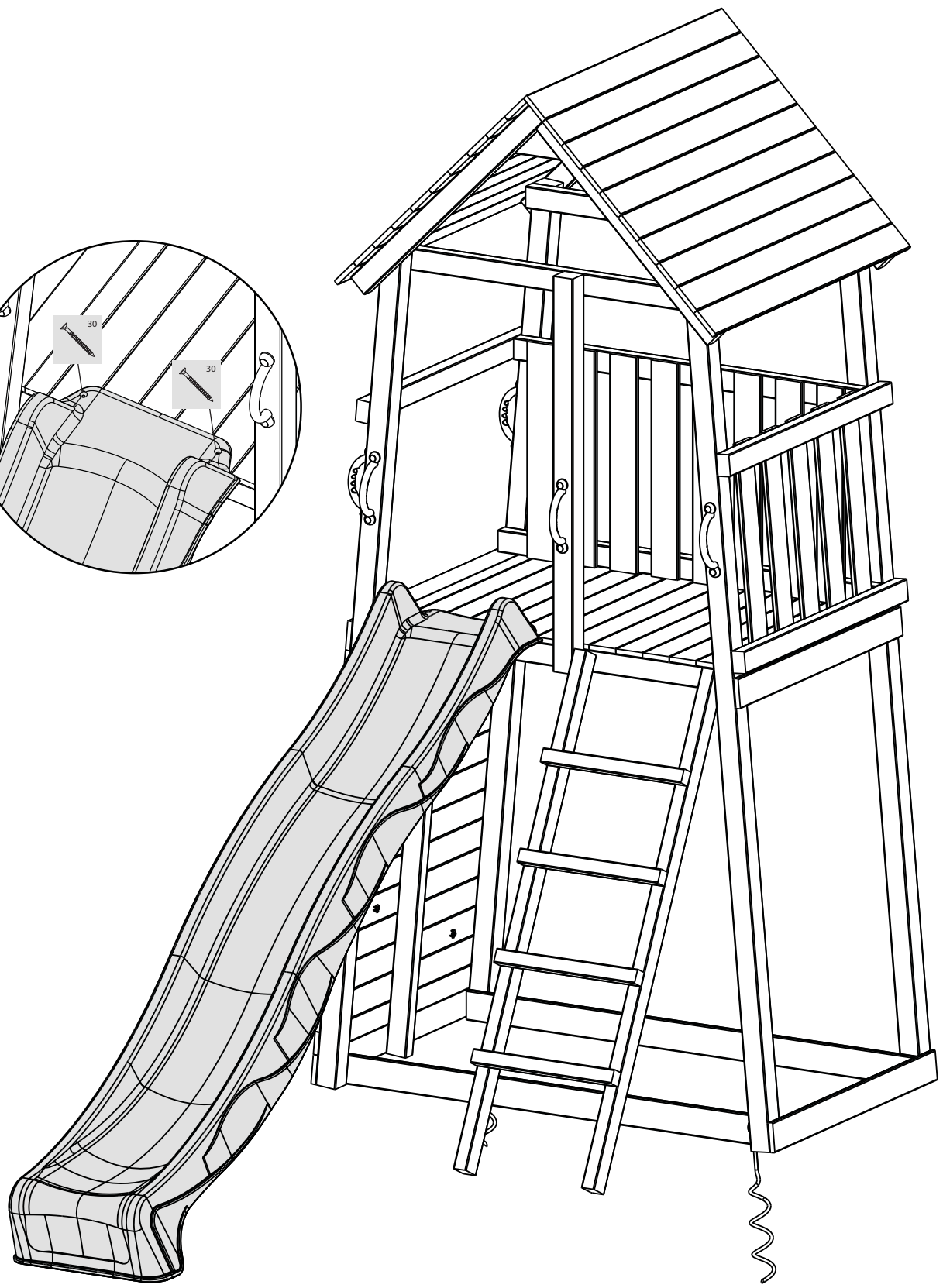
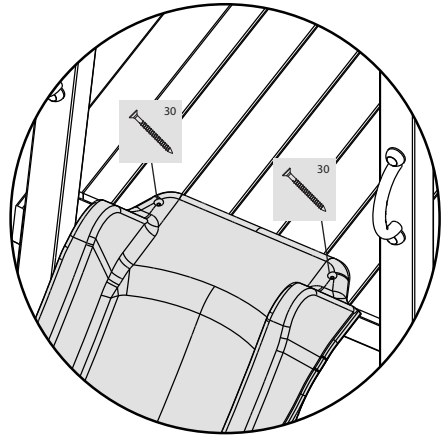



blue rabbit

Blue Rabbit 2.0®
Hemelrijken 8
B-2890 Sint-Amands
BELGIUM

www.bluerabbit.be